

# Contents

<b>1. Before Start.....</b>	<b>1</b>
<b>2. Menu tree.....</b>	<b>5</b>
<b>3. Basic Concepts.....</b>	<b>7</b>
3.1 User Enrollment .....	7
3.2 User Identification/Verification.....	8
3.3 Threshold.....	8
3.4 User ID Numbers .....	10
3.5 Privilege (status) Levels.....	10
3.6 Start-up window .....	11
<b>4. Getting Start.....</b>	<b>12</b>
4.1 Enrolling Users .....	12
4.1.1 Fingerprint Enrollment .....	13
4.1.2 Password Enrollment.....	15
4.1.3 Fingerprint & Password .....	16
4.1.4 Enroll ID .....	18
4.1.5 Enroll HID Card .....	20
4.1.6 Enroll Mifare Card .....	21
4.2 Testing an Enrollment.....	23
4.3 Enrolling a Auxiliary Fingerprint of User .....	23

4.4 Authentication type .....	24
4.4.1 Fingerprint authentication.....	24
4.4.2 Password authentication .....	28
4.4.3 RF/ MIFARE card authentication .....	29
4.4.4 MIFARE card authentication .....	30
4.5 Hints for Successful Enrollments.....	32
4.6 Enroll Administrator.....	33
4.7 Delete enrolled Data.....	35
<b>5.Option.....</b>	<b>37</b>
5.1 System Option.....	38
5.1.1 Set Current Date Time .....	38
5.1.2 Changing the Date Time Format .....	39
5.1.3 Changing the language .....	40
5.1.4 Lock .....	41
5.1.5 Unlock .....	42
5.1.6 About daylight save time .....	42
5.1.7 Advance Option.....	45
5.2 Power Manager .....	51
5.2.1Power Option .....	51

5.2.2 Time State Selection .....	54
5.3 Communication Option .....	58
5.4 Log Options .....	61
5.5 Access Control Option .....	62
5.5.1 Brief Introduction to Access Options.....	64
5.5.2 Verification Flow of Access Options .....	66
5.5.3 Function Description .....	67
5.5.4 Dress Options.....	82
5.5.5 How to set the number of failure to verify .....	86
5.5.6 Group Verification .....	87
5.6 Auto Test.....	87
<b>6.How to Manage USB Flash Disk .....</b>	<b>89</b>
6.1 Download the attendance data.....	89
6.2 Download Staff Data .....	90
6.3 Upload Staff Data.....	91
6.4 Download SMS .....	91
6.5 Upload SMS .....	91
<b>7.System Information.....</b>	<b>93</b>

<b>8.Relieve Alarm .....</b>	<b>95</b>
<b>9.View T&amp;A Records .....</b>	<b>96</b>
<b>10.Maintained .....</b>	<b>101</b>
<b>11.Troubleshooting .....</b>	<b>103</b>
<b>Appendix .....</b>	<b>107</b>
U flash disk management .....	107
State key .....	109
Time Ring .....	109
External Fingerprint Sensor .....	110
Modem Function .....	111
About GPRS .....	118
WIFI function .....	119
Query function .....	121
Print Function .....	121
MP3 function introduction .....	124
Short message management (Optional) .....	128
Multi-combination Authentication Mode .....	130
Card Support (HID, iCLASS, EM, Mifare Card) .....	134
About Anti-pass back function .....	135
Remote server Solution .....	139
iClock Time & Attendance .....	142
Web Server Access Control .....	144
Collect IP Address Automatically .....	145

About Wiegand.....	146
Understanding SOAP.....	150
About POE Power over Ethernet .....	151
Reserve Battery Mini-UPS .....	153
9 Digit Code .....	156
Automatically Synchronize Time.....	156
Daylight Saving Time.....	157
Assign time to play voice (by time period, group).....	158
Work code.....	160
DHCP .....	162
T9 input method.....	163



# 1. Before Start

## Must to know

**Notice: Do not attempt to service the machine yourself, except as explain in your online documentation or in instruction otherwise. Always follow this user guide closely.**

- Please do not place the product in the place with strong light, because the strong light may significantly affect the fingerprint scanning, and thus cause the fingerprint verification fail. This product is designed for indoor installation, if it has to be installed it outdoor, please place the equipment in proper environment, you must beware of not exposing it to wet or harsh condition, the product work temperature rang is 0-40°. Do to use you machine in every hot environment, keep you machine away from the heat source and radiator. For long time use it outdoor and the internal heat of the machine, will cause problem to the operation
- Fingerprint identification machine is a precision electronic machine, all safety and operation instruction should be read before the product is operated.
- The products warranty does not cover defects or damages arising from the lock defects, improper installation, lack of or improper

maintenance, improper storage, shipping and handling, ordinary wear and tear , misuse abuse, accident unauthorized service or use with unauthorized service parts.

**Fingerprint Enrollment and Identification shall be taken after the installation the fingerprint identification machine**



Enrollment      Installation      Identification



Enrollment      Installation      Identification

## How to place the finger

Make sure the fingerprint image captured is of a core of presented finger, a fingerprint is point to locate within innermost recurring ridge of any give finger.

To obtain a higher success rate, enroll same finger 3times in a slightly adjust angle, one to the center, one incline slightly to the left. The third incline slightly to the right. You follow the following place procedure; the success rate will increase dramatically.

**The correct way is:**

**Place a finger flatware on the sensor surface**

**Place it to the center of the sensor surface**

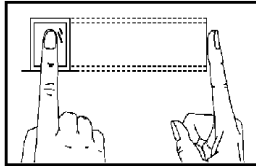

**The wrong way is**

**Vertical**

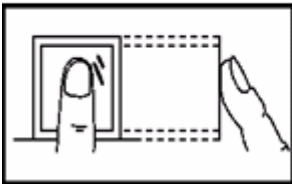

**Offset**

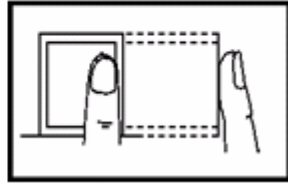

**Inclined**

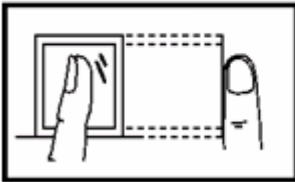

**Lower**

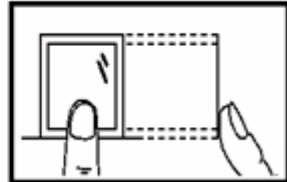

**Notice: Please adopt the correct way to place the finger; Our Company is not liable for any damages and troubles whatsoever arising out of from improper pressing manners.**

## Understanding the Operator Panel LEDs

The operator panel LEDs signify different, depending on their sequences. LED s that are off, on or blinking indicates fingerprint machine work.

- 1.** Normal work.  
Green light blinks each second.
- 2.** Failure authentication  
Red light shines for 3 second
- 3.** Verification successful  
Green light shines for 3 second

**Note: If the fingerprint machine LED don't follow above description. Please contact us to get technical assistance**

## 2. Menu tree

□ Indicates this menu item only appear in specific and customize fingerprint machine, this manual give a special instruction.

Before Start

---

## 3. Basic Concepts

This section contains definitions and descriptions of the fingerprint Identification system concepts including

- I User Enrollment
- I User Verification
- I Match Threshold Levels
- I User ID Numbers
- I Privilege (Status) Levels

The two most important Functions to Fingerprint Identification are user enrollment and user verification.

### 3.1 User Enrollment

Enrollment is the procedure to create an ID number and scan a user's finger to create a template three times. This template is associated with a user ID number and stored up.

Though the stored fingerprint reference template match against place user's finger, this fingerprint template is used to identify user's Identity, so an enrolled user is able to achieve the time clock in the appoint machine, the whole procedure take about 2 second,

for the same ID number the up to ten different fingerprint ability to be enrolled, the user may own much more verification way.

Ideally. Every finger on each hand should be enrolled, so that if a enrolled finger is injured, to alternate the backup finger is available, in normal condition, it is better that last two finger is enrolled, like, left or right index finger, so the user ability to use his (her) any finger to identify and keep away the troubles is duo to he (her) forget which finger has been enrolled

## **3.2 User Identification/Verification**

The process of comparing place user's finger against the stored fingerprint reference template. when a user either input an ID number or places a finger in the fingerprint sensor, then input password or press fingerprint, after verification process carry out, the system will show whether identify failure or success and store up the successful result to equipment Verification occurs when a user either enters an ID number or places a finger in the fingerprint sensor, then input password for comparison with the stored template.

## **3.3 Threshold**

Threshold - A predefined number, often controlled by a biometric system administrator, which establishes the degree of correlation necessary for a comparison to be deemed a match. If the score

resulting from template comparison exceeds the threshold, the templates are a “match” (though the templates themselves are not identical).

The Threshold establishes a balance between False Acceptance Rate (FAR) and False Rejection Rate (FRR). FAR mean the probability that a biometric system will incorrectly identify an individual or will fail to reject an impostor. The rate given normally assumes FRR measure the probability that a biometric system will fail to identify an enrollee, or verify the legitimate claimed identity of an enrollee.

You can set the threshold to all users. For a user who’s the fingerprint verification is difficult, you can adopt ID & Fingerprint verification (match one to one).

Raising the threshold increases security, while lowering it increases pass. The correct balance is vital. For a user whose finger is worn or injured, the threshold should be reduced.

**Notice:** FAR and FRR affect each other, if increases FAR then reduce FRR. The default Threshold is 35, 1:1 matching Threshold is 15.

**Table 1—1 Suggested Threshold Settings**

FRR	FAR	One-to-many	One-to-one
High	Low	45	25

Middle	Middle	35	15
Low	High	25	10

### 3.4 User ID Numbers

Before beginning fingerprint enrollment, a user is assigned User ID Number. This ID number is used to call up the fingerprint template or password each time that verification is requested.

ID numbers are normally inputted via the keypad, but they can be called up by other means of such as RF Card, Mifare Card (the realizing function condition is that there is card reader in the machine)

### 3.5 Privilege (status) Levels

Privileges are permission that is give to use. These define the ability of user to perform specified administrative and other task, including the ability to view, edit, add, or renew specified information categories.

Privilege levels are named set of permission that can be modified as required, User's four privilege levels are assigned by the fingerprint machine, that are user, enroller, administrator, Super administrator( supervisor).

The Fingerprint Identification systems have four Privilege or status levels:

I Users are people whose identity must be verified, such to gain access to a facility or to have their attendance recorded.

I Enrollers are Users who are authorized to enroll new users or delete on to the system.

I Managers can do other operations, except set advanced option and enroll manager's privilege.

I Supervisors are Users who access to all functions and change all setup in the system.

**Note: if there is no the Manager and Supervisor status in the system, the Enroller will enroll them. And if there isn't a Supervisor in the system, the Manager will enroll him.**

### 3.6 Start-up window

Press the power button and the screen showed on, a display of a window was called the Start-up window. The following appears:

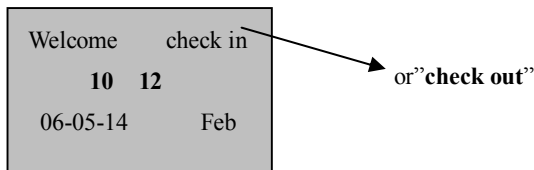

## 4. Getting Start

This chapter describes how to enroll and verify users on the Fingerprint verification system

The following topics are included:

- I Enrolling User
- I Testing an Enrollment
- I Enrolling a Auxiliary Fingerprint of User
- I Verifying Your Identity
- I Hints for Successful Enrollments

### 4.1 Enrolling Users

After setting up your fingerprint machine, the machine power on, you may enroll the user. If this is the first enrollment in a new or empty system, everyone will become an enroller, if there is a administrator in the system, you should be allowed by a administrator to enroll a new user.

This machine provides with three ways to enroll, such the Fingerprint Enrollment, the Password Enrollment, the Fingerprint and the Password Enrollment. Above three kinds of ways are correspond equal to different personnel whose fingerprint quality is different. The Fingerprint Enrollment is suitable to the personnel whose fingerprint quality is quite good; the fingerprint and the

password are suitable to the personnel, whose fingerprint may be enrolled successfully, but the verification process is the quite difficult; the Password Enrollment is suitable to the personnel whose fingerprint is unable to enroll successfully. According to the actual situation, you may select a proper enrollment way.

To start the enrollment process, identify yourself firstly—press [Menu], enter your ID number or fingerprint, and then verify your identity.

**Note: If this is the first enrollment in a new or empty system, you will not be prompted for verification.**

## 4.1.1 Fingerprint Enrollment

- 1 Press the MENU button to enter the User enroll Access the

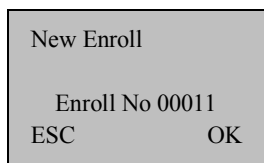

Enroll Fingerprint to press [OK], the following display:

**Note this fingerprint machine default enrolling number is 5 digit, if youu enrolled number does not arrive 5 digit, the machine will add 0 in front of this figure , E.g. your number is**

**11, the 00011 will be displayed in the machine.**

2 Input the enrolling number (the range is 1 to 65534), press [OK],

The following appears:

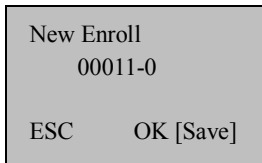

```
New Enroll
  00011-0
ESC      OK [Save]
```

**Note 00005-0**  
**The last number 0 means**  
**The first fingerprint**

3 If the test is successful three times in a row, the following

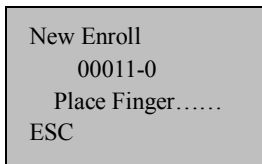

```
New Enroll
  00011-0
  Place Finger.....
ESC
```

appears:

4 Press [OK], the previous message continues to be displayed while the template is created. If your identity cannot be verified, you are prompted to try again. And you must restart the verification procedure (Step 2).

## 4.1.2 Password Enrollment

- 1 Press the MENU button to enter the User enroll Access the

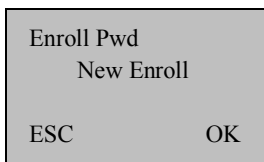

password enrollment, press [OK], the following appears:

- 2 Press [OK], the following appears:

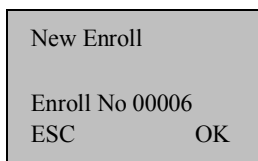

- 3 Input the enroll number (the range is 1 to 65534), press [OK], the following appears:

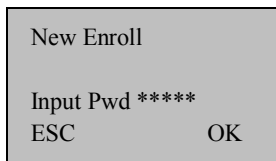

- 4 Input your password, the following appears

New Enrollment  
Input Pwd \*\*\*\*\*  
Pwd Affirm \*\*\*\*\*

New Enroll  
00006-P  
ESC OK [Save]

**Note 00006-P**  
**The last letter P means**  
**password.**

5 Input the passwords again, press [OK], the following appears:

6 Press [OK], the previous message continues to be displayed while the template is created.

### 4.1.3 Fingerprint & Password

1 Press the MENU button to enter the User enroll Access the

FP& Pwd  
New Enroll  
ESC OK

Fingerprint& Password, press [OK], the following appears:

2 Press [OK], the following appears:

3 Input the password (range is 1 to 65534), press [OK], the following appears:

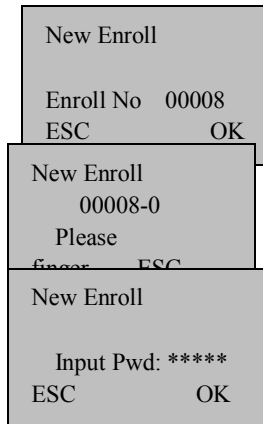

4 If the test is successful three times in a row, the following appears:

5 Input your password, the following appears:

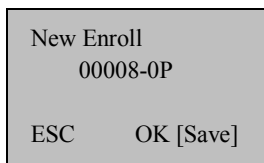
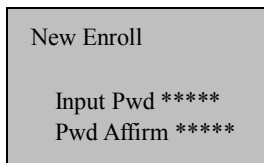

6 Input the password again, press [OK], the following appears:

7 Press [OK], the previous message continues to be displayed while the template is created

**Note 00008-0P; the second from the last 1 means one fingerprint, The last letter P means password.**

## 4.1.4 Enroll ID

1 Press the MENU button to enter the User enroll Access Reg

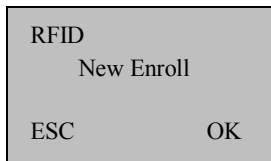

RFID, press [OK], the following appears:

2 Press [OK], the following appears

3 Input the enroll number (the range is 1 to 65534), press [OK], the

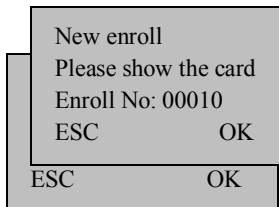

following appears

4 Slip the card near the area of induction follow the prompt, read out Card ID, the follow appear:

5 Press “**OK**” key to complete Enrollment go on next operation.

New Enroll  
RFID 16650449  
Enroll No: 00010  
ESC OK

New enroll  
000010-C  
ESC OK

**Note 00010-C**  
**The least letter C means ID card**

the following appear

6 Press “**ESC**” key to cancel the new enrollment, press **OK** to save enrolled data, so that complete registering ID card flow

**Note IDcard is a option function on the fingerprint machine, if you want to customize fingerprint machine with ID card function, please contacts our market supporter and sale. If you want to know more information please refer to (ID card use**

guide)

### 4.1.5 Enroll HID Card

This operation procedure is same as ID Card operation, use HID card only by Using 125MHZ,13.56 MHz contactless smart card technology only, these fingerprint products provide users with new options for supporting multi-authentication of identity. Combine a contactless card presentation with a fingerprint biometric. Or, use a personal identification number (PIN) number along with a contactless card presentation. (See multi-authentication)

HID standard card is encrypted by using specify format encode card ID and the equipment code.

**Note** HID card apply to fingerprint -machine, this is an option function on the fingerprint machine, if you want to customize fingerprint machine with HID card function, please contacts our market supporter and salesman.

## 4.1.6 Enroll Mifare Card □

- 1 Press (MENU) KEY on the initial interface, after your privilege

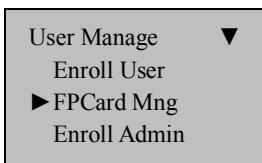

are admitted, follow information appear on the screen

- 2 Press (ok) Key, enter next operation. Information show follows

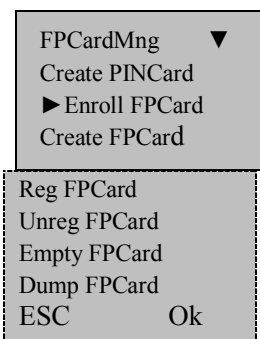

There are eight sub-item, which is create fingerprint card, enroll fingerprint into card, register fingerprint card, cancel fingerprint

card, erase fingerprint from card, copy fingerprint from card, transfer fingerprint to card, the each follow detail explain is for eight sub-item.

**1. Create PIN. Card** (Create PIN card): utilize registered user in the fingerprint machine to Create PIN card, user may use the card to identify himself, and don't place the finger.

**2. Enroll fingerprint into card** (Enroll FP card): directly store the fingerprint that has been register into card, at this time there is a fingerprint in the card, and that does not exist in the machine, user may use "Card + Fingerprint" to identify himself, must punch the Fingerprint card firstly, than place finger.

**3. Create Fingerprint Card** (Create FP Card): copy fingerprint from the fingerprint machine in which exist to a Card, user can use the fingerprint to verify, also can utilize a fingerprint and a Fingerprint Card to verify.

**4. Register Fingerprint Card** (Reg FP Card): there is more than two attendances machines, A enroll PIN. Card has been registered in one fingerprint machine, which want to be use to anther fingerprint machine, the Fingerprint Card must be registered firstly.

**5. Clean Fingerprint Card** (Unreg FP Card): this operation is a reverse process to above operation

**6. Erase fingerprint from Fingerprint** (Empty FP Card): clear all data (fingerprint, PIN) on the fingerprint card.

**7. Copy Fingerprint from card.** (Dump FP Card): Copy a fingerprint from a card to Fingerprint machine, it is able to directly track attendance by fingerprint after finish this operation process.

**8. Transfer fingerprint into card** (Move to FP Card): the fingerprint in fingerprint machine is transferred to a Fingerprint Card. there is not fingerprint in the fingerprint machine after transferred.

**Note Mifare card is an option function on the fingerprint machine, if you want to customize the fingerprint machine with Mifare card function, please contacts our market supporter and salesman's. If you want to know more information please refer to (Mifare Card use guide)**

## **4.2 Testing an Enrollment**

Ask the users to place their finger to perform test . If the test was successful, you will adopt Fingerprint enrollment. If the poor quality of fingerprint, you will be recommended to use Fingerprint & Password.

## **4.3 Enrolling a Auxiliary Fingerprint of User**

For a long time using, if tthere is space in the system memory to

store, it is better to enroll more than two fingerprints a user. Enter the new enrollment interface Press 'OK' key to continue performing the new user enrolling, Press 'ESC' key to cancel the new enrollment, and to enter the backup enrollment interface, the following appears:

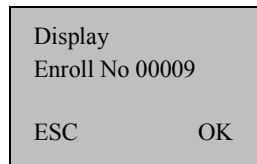
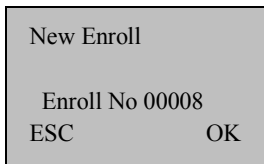

This operation procedure is same as above enroll new user operation

**Note:** Where system memory permits, it is advisable to have at least two fingers enrolled for a long-term user.

## 4.4 Authentication type

### 4.4.1 Fingerprint authentication

Use fingerprints to validate access authentication with the following types:

#### 1 1 1 authentication Verification

In this mode, enter a pre-registered ID first and then a fingerprint. The enrolled fingerprint corresponding to the ID will be compared to the entered fingerprint on a 1:1 basis. The 1:1 authentication type takes a short time regardless of the number of users. There is no need to make any special settings in the system. After entering the ID, enter the fingerprint to perform authentication. Block diagrams of enrollment, verification, and identification tasks.

### **Operational trip**

In the initial interface, enter your ID number, the following appears:

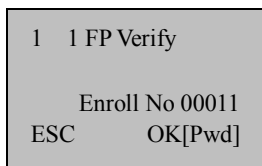

**Note** This fingerprint machine default enrolling number is 5 digit, if you enrolled number does not arrive 5 digit, the machine will add 0 in front of this figure , E.g. your number is 11, the 00011 will be displayed in the machine.

Press “OK”, then Place the finger on the sensor surface, the following appears

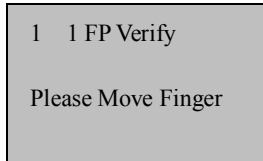

It continues for about 0.5 seconds. If the test is successful, it will say “Thank you”, the following appears:

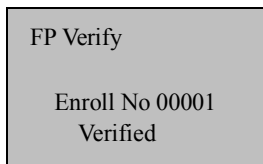

If your identity cannot be verified, you are prompted to try again, the following appears:

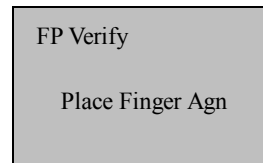

It continues for about 0.5 seconds, return to the start-up window.

## **2 1 N authentication (Identification)**

Only enrolled fingerprints are used for authentication. Though the authentication procedure is simple, this method will take a little longer than the 1:1 authentication if there are many users. There is

no need to make any special settings in the system

### **Operational trip**

Place the finger on the sensor surface, the following appears:

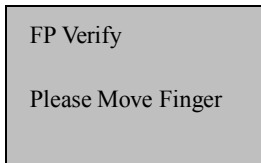

It continues for about 0.5 seconds. If the test is successful, it will say “Thank you”, the following appears:

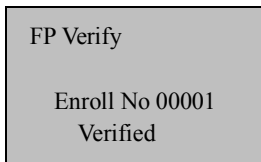

If your identity cannot be verified, you are prompted to try again, the following appears:

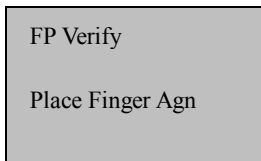

It continues for about 0.5 seconds, return to the start-up window.

### **1: G; 1: H (Group authentication)**

For group authentication, user can define a range of user ID, if user

ID is within the range, authentication way must be 1: N, otherwise the authentication procedure is 1:1 matching.

--1: **H authentication:** user must input the advance part ID to perform fingerprint authentication, if the input ID is entire No., the system will carry on 1:1 authentication,

--1: **G authentication:** the user must be grouped before authentication, you can specify a group ID of 1--4 digits long for each user group. You will enter a group ID and press down -key, and then place a fingerprint for authentication. You can specify a group ID when you register a user. Unlike other methods, you must enter the group ID, and then press down-key before entering the fingerprint to perform group authentication.

## 4.4.2 Password authentication

A password of 1--5 digits long is used to validate authentication. You can use this method in such a special case as when the fingerprints are damaged

To start the enrollment process, enter your ID number, the following appears:

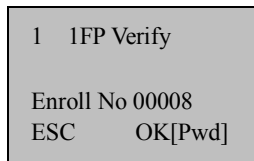

1 1FP Verify  
Enroll No 00008  
ESC OK[Pwd]

Press [OK], the following appears

Pwd Affirm	
Enroll No	00008
Input Pwd	*****

Input correct password, press [OK], the following appears:

Pwd Affirm	
Enroll No	00008
Verified!	

If the password cannot be verified, the following appears:

Pwd Affirm	
Enroll No	00008
Error Pwd	

#### 4.4.3 RF/ MIFARE card authentication

The RF card of a user is used to identify the user. You can register the RF card number to the system in advance to provide against loss or theft of the RF card.

#### 4.4.4 MIFARE card authentication

The MIFARE card is a contact -less IC card, 1K card has its 1 K byte memory assignment as 16 sectors, each with 4 blocks of 16 bytes. The MIFARE card interacts with the reader, which is able to store fingerprint template inside, the fingerprint template is transferred to reader, then the template against placed finger while use performance verification.

The MIFARE card also own unique serial No. you can use it instead of ID card. **(For more detail see appendix.)**

If the Mifare card has been used as created PIN card, need to enter “Menu→Option→System Option→ advance Option”, press “▲/▼”, select “No. Card” as Y (es), the validating as follow.

In the starting-up windows. place the PIN card near induction area ( distance is not far, otherwise the card will not be detected) the screen show as follow

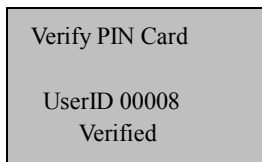

If use other way to register Mifare card (the example: The registration fingerprint card), Set “No. card” option as Y (es), then step same with above.

If Set No. card” option as N (O), then confirmation flow as follows:  
In the initial interface, (distance is not far, otherwise the card will not be detected), screen display as follows:

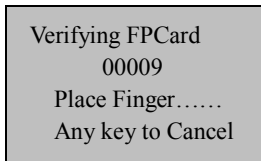

Verifying FPCard  
00009  
Place Finger.....  
Any key to Cancel

Place the finger on the sensor surface, the following appears

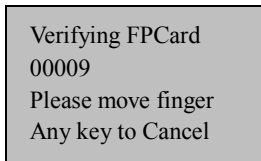

Verifying FPCard  
00009  
Please move finger  
Any key to Cancel

It continues for about 0.5 seconds. If the test is successful, it will say “Thank you”, the following appears:

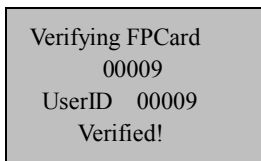

Verifying FPCard  
00009  
UserID 00009  
Verified!

If your identity cannot be verified, you are prompted to try again, the following appears

Verifying FPCard  
00009  
Please try again  
Any key to cancel

It continues for about 0.5 seconds, return to the start-up window.

**Note: beside of above authentication type, multi-authentication also is privoded. See Appendices. If you want to this function please contact our market support or salesmen.**

## 4.5 Hints for Successful Enrollments

If the fingerprint is of good quality, the verification speed will fast; otherwise, it will verify slowly or occur to FRR. In order to improve the fingerprint verification quality, the following hint appears

Trouble	Solution
Fingerprints is too dry or dirty	Solve the dry problem that rubs the dry finger with palm. If the fingerprint is dry, you should adopt the way of wetting up the finger, such as brow air over finger.
Have no enough to bring pressure	The user should place a finger firmly and flat on the sensor surface.
How to select	Recommend to left or right index or middle finger. Use fingerprints of good quality, without worn or injury.

the finger?	The user usually selects the forefinger, if it was of a poor quality, you will be recommended to middle finger or ring finger. If the user's finger is small, you will select the thumb.
How to place the finger?	Place your finger firmly and touch the sensor surface must be over 2/3. The fingerprint does not touch upright on the sensor surface. Do not touch the finger too fast; Do not move the finger on the sensor surface.
The effect of the fingerprint pattern change	For a user with worn or injury finger, the identification can be affected. If the finger quality was poor, you should be select password to verify.
Others	However, few people's fingerprint quality is too poor to verify, the fingerprint in gear. Please use ID & fingerprint verification, and the Threshold can be reduced or use password verification.

## 4.6 Enroll Administrator

In order to prstate unauthorized personal change the option of the machine, the machine provide an option to set administrator.

1 Enter the menu of the machine after verify successfully, the

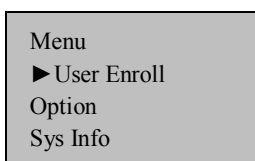

following window appear

2 Press **OK** key Enter user managerment,the following windows

appear

3 Using “▲/▼” key, select manager to enroll, the follow interface

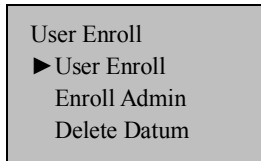

appear.

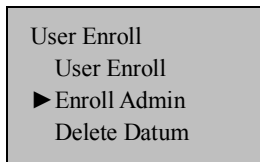

4 Press **OK** key Enter management enrollment the following window appears.

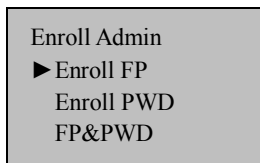

5 You can select a favor way to register an administrator, the administrator authorization includes enroller authorization, manager authorization, and super administrator (supervisor) authorization, more detail see privilege level. The enrollment way is same as user

enrollment.

## 4.7 Delete enrolled Data

If a user wants to be deleted, you can take following step to cancel the user.

- 1 Press **Menu** Enter the machine menu after verify successfully,

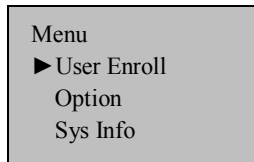

the following window appear

- 2 Press **OK** key Enter user manager, the following window appear

- 3 Using “▲/▼” key, select data to enroll, the follow interface

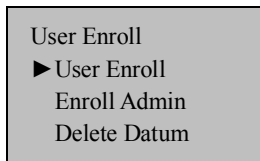

appear.

4 Press **OK** key Enter the process to cancel data the following window appear.

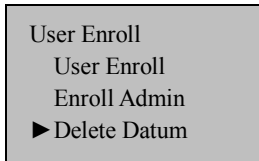

5 input the number you want to cancel, pressOK to confirm, go on

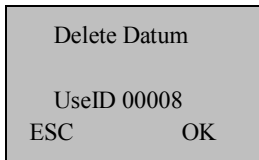

next operation, follow the prompt on the window to cancel user.

## 5.Option

Press the [Menu], and then verify your identity. The following appears:

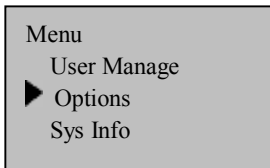

Access Options, press **[OK]**, the following appears:

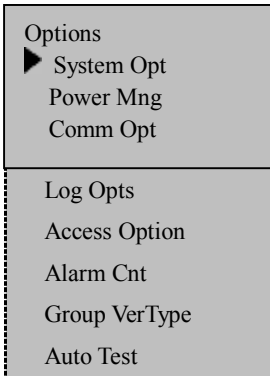

This following topic included: System Option, Power Manage Communication Option Log Option and access option, Auto test. Alarm Cnt, GroupVerType. The Alarm Cnt (Amount of failure to verify until sending alarm) and GroupVerType (Verification by group type) is an optional item, there are only in access control machine.

## 5.1 System Option

Access System Opt, the following appears:

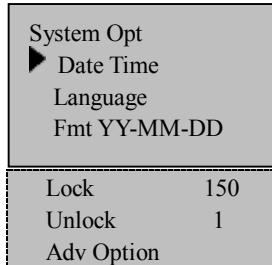

The setup facility covers four areas: System Options, Language, Lock and Advanced Options.

### 5.1.1 Set Current Date Time

Access Date Time, the following appears:

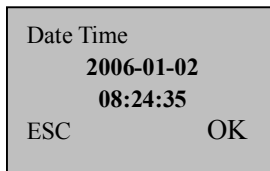

To change the date, press **ESC** and key, then input the correct date and time, press **[OK]**

## 5.1.2 Changing the Date Time Format

Access **Fmt YY-MM-DD**, press **←** and **→** key, then input the correct date and time format, press **[OK]**

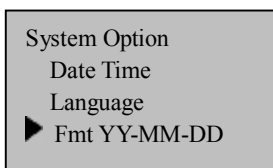

There are ten formats **YY-MM-DD** **YY/MM/DD** **YY.MM.DD**

**MM-DD-YY** **MM/DD/YY** **MM.DD.YY** **DD-MM-YY**

**DD/MM/YY** **DD.MM.YY** **YYYYMMDD**. For change the Date

Time display format in the initial interface.

E.g. **YY/MM/DD** format (left) become to the **YY-MM-DD** format

right

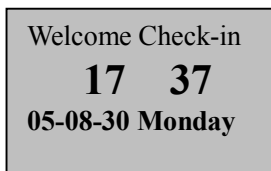
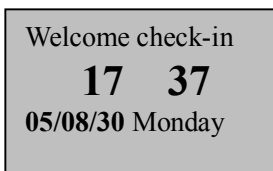

### 5.1.3 Changing the language

Select the language you want and press OK, the default language is English; the screen will show in English.

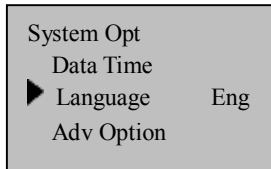

Scroll the up down key to change the type of language, the machine fully supports multinational languages, on the screen there may be display as English besides the language you favor and order.

Choose the language you want, and press OK then press ESC to exit system option, the system may prompt you to save the setup, press to confirm and change the system language setup. Be sure to restart you computer .so the setting take effect

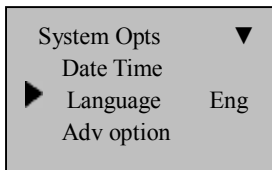

English

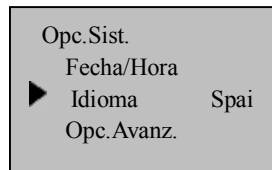

Spain

**Note This fingerprint machine does not provide this option that follows that standard approved for use with this machine, if you need this function; please contact our market supporter or salesman.**

## **5.1.4 Lock**

The Lock means the duration of lock drive, fingerprint machine controls the time how long to open electronic lock. Select this option, and press OK key to enter setup, key in figure through digital key, press ESC to exit and save the setting.

This duration criterion unit is 20 ms, which max value is 254, namely 5.08seconds. “0” means this function is in closed

**Note This is an optional setup, this option only exists in the fingerprint machine that own simple Access Control function. If the fingerprint machine is a specialty Access Control machine, which contains this option.**

**Above parameter of the duration of lock drive follow that standard approved for use with this machine. If you want to know much more parameters. Please contact our market supporter or salesman.**

### **5.1.5 Unlock**

This option means how many personal can unlock, Select this “Unlock” option, and press OK key to enter setup, key in figure through digital key, press ESC to exit and save the setting.

Default value is 1, that means only one user is able to unlock when his verification is positive, if this value is set as 3, that means the fingerprint machine send a unlocking signal till only all three user verify successfully, the interval of each personal is on more than 30 seconds. The max value set as 5 is available.

### **5.1.6 About daylight save time**

Summer time, also called the "daylight saving time" (Daylight Saving Time), is desginted for energy conservation and a local time system, the system is used during the implementation unified time known as "daylight saving time." Usually in the early dawn of the summer day people will be ahead one hour of time, people can get up early , reducing lighting in order to make full use of resources illumination, save electricity lighting power. To back again one hour in autumn. The daylight saving time has the specific requirements in the different countries. At present there are nearly 110 world countries each year to use the daylight saving time.

In order to meet the needs of daylight saving time , we can open a specialized custom settings in the fingerprint machine, in the XX,

XX-XX, XX-time hours, one hour faster, and by XX, XX-XX-XX, then slow down a time hours.

[Instructions]

machines that support this functions, enter the menu -> Option -> System Option -> the "daylight saving time" setting.

1) Perform the options the daylight saving time can be set. shown as the following:

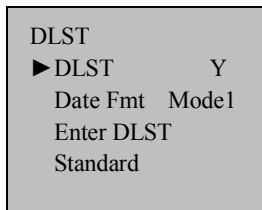

Choose the daylight saving time to "Yes", after setting completed, press OK to save, this setting will take effect. If choice is "No", then daylight saving time function will be ineffective.

2) after the daylight saving time function is activated, it is need to configure starting and end events of daylight saving time. Set the time format conversion, There are two modes of Mode 1 and Mode 2.

If you choose a mode 1 that is defaulted by system: its time format shown as " the month, day    hours: minutes"

If you choose the mode 2 of the daylight saving time "Month - Weeks- week    hours: minutes" mode.

Be allowed to input range is 1-to-6 for the number of weeks (WS),

if 1 you input means the first week, said that the second week if input with 2, and so on. Allow to input range is 0 - 6 for each Week (WK), if you input 0, 1 these 0,1 respectively represent the Sunday Monday, and so on.

We take at 4:00 on September 1, 2008 (ie, in September 2008 the first week of the week 6) as an example, these two models of Mode

MM-DD 24H			
9	1	04	00
ESC		OK	

MM-WS-WK 24H			
9-1-6		04	00
WK	0	Sun	6:Sat
ESC		OK	

1 and Mode 2

Mode 1

Mode2

[Note]

1, if the begin month of the daylight saving time that you set is bigger than at the end of time, that means the setting over a year . like this : begin at 2007-9-1 4:00 and end at 2008-4-1 4:00

2, if you choose Mode2, enter the daylight saving time is: September Sunday, the sixth week of month, this year is 2007, then upon 2008, there is not the sixth week to check from the calendar, only the five weeks, In such circumstances, the system will assign the last Sunday of this month the corresponding time that points into the daylight saving time.

3, If it is set to enter the the daylight saving time is: September the

1th week Monday, the current year is 2008, then upon 2009, according to the calendar, the first day is Tuesday, instead of Monday, in which case , the system will automatically find the first Monday in this month

4, this funcation non-standard provided, for detail about this function machines, please consult our business duputy or pre-sale technical supporter

### 5.1.7 Advance Option

Access Advanced Option, press [OK], the following appears:

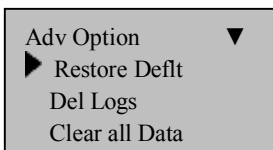

Clr admin pri	
Show Score	
Match Thr	45
Only 1 to 1	N
1:1 thr	25
Two sensor	N
Voice	Y
No.Card Only	N
R.card Only	Y
FP Card Only	Y
Upd firmware	
Remote Auth	Y
Auth Server	
Work code	N
Button Beep	Y
AdjVol(%)	34
Print	

scroll “▲/▼”to up or down the screen to select the option.

- n **Restore Default:** restore all setup information to default of leave factory.
- n **Clear all Data:** delete all enrolling user information and logs.
- n **Delete Logs:** delete all logs of flash disk.
- n **Clear Admin' Privilege:** change the Administer privilege into ordinary users' option.
- n **Show Score:** whether show the quality value of fingerprint in the screen or not.

- n **Threshold:** For helping in selecting threshold level settings, see Table 1--1
- n **Only 1 to 1:** whether the staff's ID number must be input.
- n **1:1 Threshold:** when use ID+ fingerprint to verify set the Threshold level
- n **Two Sensors:** if need to connect a external additional Sensor, choose the option as “**Yes**”  
**Note: After connect with fingerprint sensor; be sure to restart the fingerprint machine, so the sensor takes effect.**
- n **Sound:** whether use to phonic hint or not. If set the option as (**Yes**), the machine will send a hint sound for every operation example, after the verification is successful, the machine will say (**Thank you**), if set the option as (**No**) the machine will not send sound Hint, only utter one (**do**) sound after the verification is positive, when the verification is negative, the machine utter two (**do**).
- n **Firmware Upgrade:** if want to upgrade the firmware of machine, may use the USB flash disk or connect the machine to the PC, carry out the operation process.  
**Caution: The user does not random upgrade the firmware, you must be allowed by the dealer before to upgrade the firmware, voluntarily upgrade occur the question which possibly affect your normal use.**

- n No. Card** This item is set as “Yes”, only verify No. card to pass authentication. If this item is set as “NO”, after verifying Card, must go on fingerprint verification.
- n R.Card Only** This item is set as “Yes” must register card on the fingerprint machine first; if this item is set as “No”, need not to register card.
- n FPCard Key** After this item is set, the fingerprint machine will be able to write in password to the card which has been register in the fingerprint machine.
- n Remote** After this item set as “Yes”, this fingerprint machine can be used in Remote Identification mode.  
There are four mode to select (NL, LN NO, LO) in the fingerprint machine, these option signify different thing,  
**NL**, indicate that firstly perform network verification then local verification,  
**LN**, first perform local verification then go on network verification,  
**NO**, indicate only go on remote verification, only remote database has fingerprint to pass verification,  
**NL**, indicate only go on local verification, local fingerprint terminal has fingerprint to pass verification.

- n **AuthServer** : In the LAN the remote authentication Server' IP address.
- n **Work Code** This item set as "Yes". The machine prompt ask input work code while user go on authentication, then press OK to save it, if this item set as "NO", while go on normal verification.
- n There are two Mode 1, Mode 2. Detailed Help Please refer to Appendix work numbers
- n **Ant-pass back**  
The four options are: No, exit, in, out. Please refer to detailed features on the anti-passback capability in the Appendix
- n **Button Beep**: whether send sound hint while press key, if set the option as (Yes), then as press the keyboard the machine will utter, if set the option as (NO), when press the keyboard the machine doesn't utter.
- n **Adjust Voice**: adjust the voice volume of hint sound and keyboard sound.
- n **Imdt Prt** This item is set as RS232, when user verify successfully the fingerprint machine will export signal through serial port, if the machine connect with printer, ability to print or view it via the super terminal.

**Note: This function only support serial port (RS232) printer, the parallel interface is not to be support, the Baud rate of fingerprint machine and printer must be same with. More detail see appendix**

## **Note**

- 1) **Additional fingerprint sensor and up grade firmware** are valid for these fingerprint machine that is provided with USB port.
- 2) **No. Card** is valid for the fingerprint machine that is provided with Mifare or ID Card.
- 3) **R.Card Only. FPCard key** only are used in fingerprint machine with Mifare function.
- 4) **Remote. AuthServer** only are used in RIS function of fingerprint machine.
- 5) **Button Beep, Adjust Voice**, only applies to these fingerprint machine which use U.are.U Fingerprint sensor.

## 5.2 Power Manager

This product uses smart manage system, supports the time switch and the timetable of time switch, lock power button as well as time alternate state

### 5.2.1 Power Option

Access Power Manage, the following appears

Power Mng	▼
▶ Shutdown	N
Power On	N
Sleep	N
Bell Delay	10
Scheduled	
Idle	
Idle min	0
Lock PWRBut	N
WebMaster IP	
Time alter state	

This product uses smart manage system, supports the time switch and idle features, it can satisfy the user's different demands.

**n Shutdown:** auto shutdown follows the schedule.

Select this item .press OK key to enter following interface:

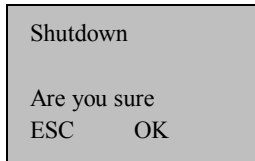

Press **Ok** key to set shutdown schedule press **ESC** to give up.

After complete setting schedule, press OK to confirm, so this function take effect.

- n **Power on:** auto power up for the schedule
- n **Sleep:** automatic resting for the schedule , press any key to enter working state
- n **Idle and Idle Minute:** they are related each other, while the idle minute is zero, the idle is closed; while the idle minute is not zero (unit was minute), for example, it is one minute, the user does not do anything in one minute, and the system will enter the idle state.
- n **Bell delay (Time ring and the duration of ringing):**The system total has eight Bell schedule to set, according to actual need you may set time bell, when the time arrive at the appointed time, the fingerprint machine will automatically

ring bell, the duration of ringing achieve assigned hour, the ringing will stop automatically.

- n Web Master IP** Set IP address of PC which has been installed Web server.
- n Adjust volume** If you don't satisfy speaker to play MP3 value of the fingerprint machine. Can use the function to adjust it.
- n Lock Power Button:** Set this option as **(NO)**, the press the power key to shutdown the machine, if set this option as **(Yes)**, the "Shutdown machine" Prompt will appear on the power manage menu, in this time the machine is no able to be shutdown, only enter the menu to choose "Shutdown machine" to realize machine off.

## Note

1. If you have not find this Option, shutdown, Power on, it belongs to the normal state. Only some machine have the time state selection function, if you have any question, please contact our technician.
- 2 Web Master IP setting is valid unless the fingerprint machine

own playing MP3 **function**. Please refer to (MP3 Function Introduction)

**3. Time ring and the duration of ringing** only belong to these fingerprint machine with **Time ring and Playing MP3** function.

## 5.2.2 Time State Selection

**State Selection** While the Time& Attendance machine under using, the different time period need to correspond checking state, the six state key allows the User to choose the desired state prior to clocking in/out.

These state key are set by manual, may press the corresponding key to select state you want, for convenience operation, There is another setting provided that allows state shift to be set either at IN or OUT in an state schedule table. The state schedule table features up to 4 entries.

**Time State Selection:** There are two fields of each state schedule table entry: time field and corresponding state mode (IN/OUT) field. When time up to the scheduled time, the fingerprint machine will automatically switch selected state at IN or OUT by your setting in state schedule table. Currently check condition will appear on the initials interface of fingerprint machine.

### How to set the time state selection

#### Setup time state selection

1 Enter menu->**Option->Power Manage->Attstate Fun** such as

Att state Fun
Check condition
On check-in
Exit (ESC)  OK(OK)

following picture

2 Press “ / ”key to select check state you want set, there are four state option that maybe set and four time period, that are clock on, clock off, overtime check-in , overtime check-out, press ok key to set, now take “ Clock out” to illustrate

Changeoffcheckout ▼
▶ Time1          N
Time2          N
Time3          N
Time4          N

3. Choose time you want set, first select time period, press OK key, such as follow:

Time 1
Set time function
No(ESC)  Yes(OK)

4 Press ok key enter following interface, directly input time you want via figure key

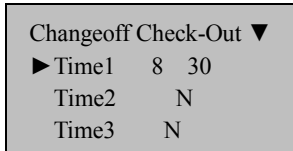

5 Press “ / ” key to select time you want set newly, as following picture.

6 After completing setting, Press ESC to exit, then the prompt will appear on the screen, follow the prompt, press Ok to save, press ESC key to exit.

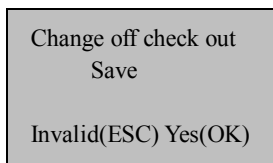

7 If this setting has been save, upon appoint time, the check state will switch clock out state.

## Cancel the time state selection

- 1 Enter set alternate state interface to cancel time of set “Clock out” state

Enter menu → option power->time alternate state, choose

Changeoff checkout ▼	
▶ Time1	8 30
Time2	N
Time3	N

“Clock out”: as following picture.

Time4	N
-------	---

- 2 Select time you want cancel, take example as the time 1. Press Ok Key as follow picture.

Time1	
Set time function	
ESC	OK

- 3 press **ESC to cancel** the time will be canceled,

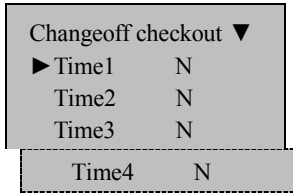

4 After completing setting, Press **ESC** to exit, now the prompt will

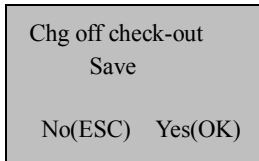

appear on the machine, press **OK** to save, press **ESC** key to exit

5 If performance saves, this option will take effect to cancel “time 1” of “Clock out”

## 5.3 Communication Option

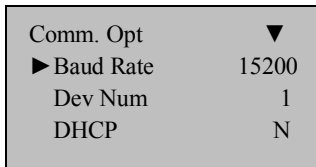

Access Comm. Opt, the following message appears

Net speed	Auto
IP address	
Net Mask	
Gateway	
TCP/IP	Y
RS232	N
RS485	N
Link code	0
Extern Modem	Y

The machine fully supports **RS232, RS485, TCP/IP**, whether the machine are used to a Single Unit or Link to Networking, it will satisfy the user's demands

- n **Baud Rate:** there are five options, 9600, 19200 38400, 57600 115200; this means the speed of communication.
- n **Machine Number:** Identity ID, the range is **1 to 255**
- n **DHCP (Dynamic Master Configuration Protocol):** whether start DHCP function in the fingerprint machine.
- n **IP address:** it defaults to IP address is 192.168.1.201
- n **Net speed:** the Net default Speed is Auto, its option is 10M-F, 10M-H, 100M-F, 100M-H
- n **Net Mask:** the Net Mask default is 255.255.255.0, as you

need to change it

- n **Gateway:** it default to Gateway is 192.168.1.1. As you need to change it
- n **Ethernet:** whether use TCP/IP protocol or not
- n **RS232:** whether use RS232 or not
- n **RS485:** whether use RS485 or not
- n **Link code:** it defaults to code is 0, but it can be set up.
- n **Extern Modem** This item is set as Y(es), this fingerprint machine may connect with additional Modem
- n **USB** : The use of USB communication, if you use USB communications, it would be the choice is "Yes", otherwise voted "No"

## Note

**1) If the fingerprint machine is provided with “Getaway” and “Sub mask”, the “Ethernet” Option will not exist in it, which is defaulted as Ethernet is in opening; If the**

**fingerprint machine is not provided with “Getaway” and “Sub mask”, the “Ethernet” Option will exit in it, if you want to use Ethernet, this Option must be set as Y(es).**

**2) After setting be sure to restart fingerprint machine, so the configuration take effect.**

## 5.4 Log Options

Access Log Opt, the following message appears

Log Opt	▼
▶ Alm SuperLog	99
Alm AttLog	99
Recheck Min	0

- n Alarm Supervise Log:** When the remainder the Manage log capacity reached set numerical value, it will automatically sound a warning that logs were full.
- n Alarm Attendance Log:** when the remainder log capacity reached set numerical value, it will automatically sound a warning that logs were full.
- n Recheck Minute:** Set it within the scope (Unit: minute). Someone’s enrollment has enrolled, then, the log twice was not displayed in the system.

## 5.5 Access Control Option

**Unless this fingerprint machine is provided with a professional Access Control function this Option does not exist and is invalid, this function does not exist in the fingerprint machine which is used in T&A and Simple Access Control.**

---

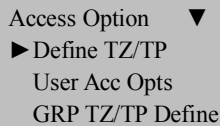

Access Option ▼  
▶ Define TZ/TP  
User Acc Opts  
GRP TZ/TP Define

Enter the Access Option, press [OK], the following appears

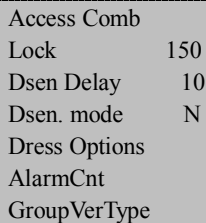

Access Comb	
Lock	150
Dsen Delay	10
Dsen. mode	N
Dress Options	
AlarmCnt	
GroupVerType	

Main function in Access Options

- n **Define TZ:** is the definition of everyday Time period that can unlock door in one week
- n **User Access Option:** is the definition User Group, User's Time period and unlock comb
- n **Group Time period:** is used to set group unlocking time;
- n **Access Comb (Unlocking combination):** defines different unlocking combinations, each combination is composed of different groups
- n **Lock (Time duration of lock drive):** fingerprint scanner controls the time to open electronic lock.
- n **Dsen.Delay** Some segment time which begin after open door just begin alarm;
- n **Dsen. mode** there are three option that is none( NONE), normal open (NO), normal close(NC) .the none means the door Sensor doesn't apply, Normal Open is defined that Thee door can be set to a Passage Mode in the normal condition, Normal Close means that the door is close in the normal work condition..
- n **Duress Alarm Option:** If the fingerprint registered has been authenticated the system will send an alarm signal to prstate

someone is forced to open door. In the menu you can do to all setting.

- n **Alarm Cnt** (the amount of failure to verify), if times of user failure to verify equal to the value set, the fingerprint machine will send alarm signal.
- n **GroupVerType**: this means user who belong to group use verification type.

**Note** This option also is an optional item. It only is owned by some fingerprint access control machine, if this option is set as Y (yes), the fingerprint machine is able to perform Multi-combination verification.

## 5.5.1 Brief Introduction to Access Options

Access Options function option is the settings of registered user's unlocking time period and unlocking combination.

Each user's attribute is defined by one belonged grouping, use group time period and user time period. Grouping is to divide users into several groups, such as group 1, group2, etc. every group include threes time period, which is named as group time period, In group time period, user can select maximum three time periods already being set. Relationships among these three time periods are "OR" (i.e. it is only need to satisfy any one of these three time periods). In user time period, user can select maximum three time

periods that has been set. Relationships among these three time periods are also “OR”.

Simply put, conditions of registered user can unlock door are:

- 1:** The group that user belongs to should be in unlocking combination (also this group can be in unlocking combination with other groups, but it is required to unlock door together with them).
- 2:** Current unlocking time should be in any effective Time Period in user time period

System defaults that new registered user belongs to group 1, default grouping combination is group 1, and default group Time Period is “1”. Under the condition that group 1 and Time Period 1 are in factory default status, new registered user defaults in unlocking status (if user changes correlative setting of Access Options, system will change according to user’s modification). If the grouping that user belongs to does not include in grouping combination setting, then user can only record attendance and cannot unlock door.

## 5.5.2 Verification Flow of Access Options

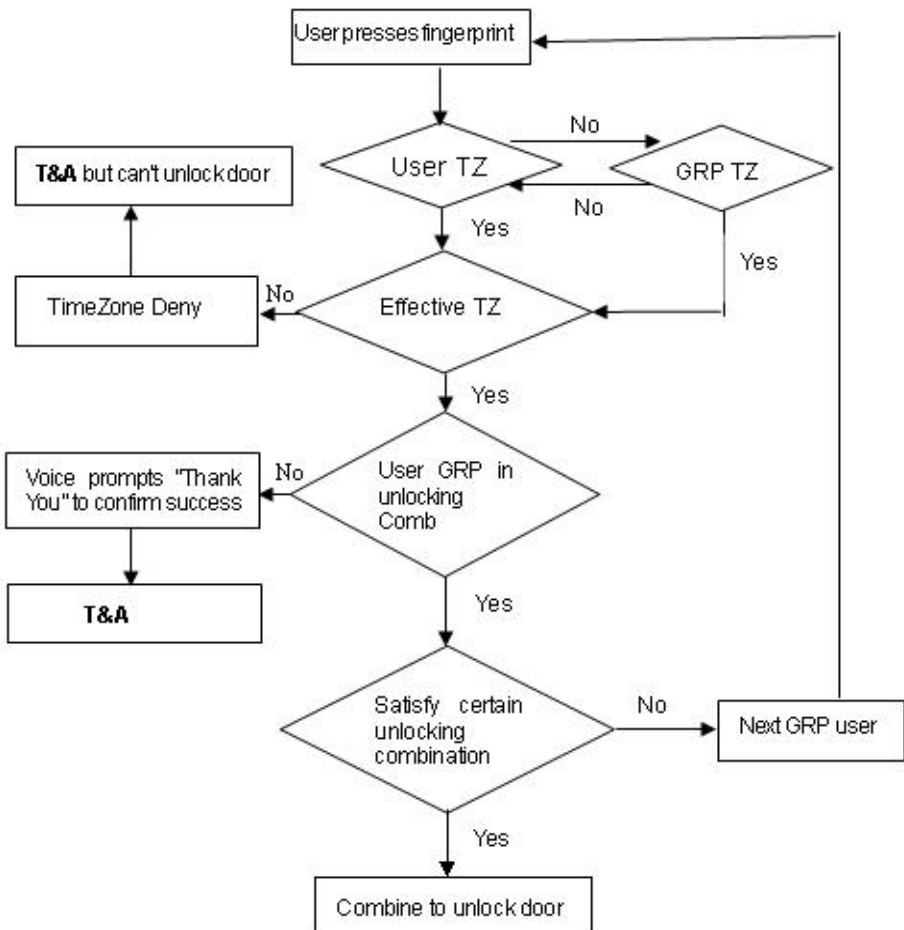

## 5.5.3 Function Description

### 5.5.3.1 Definition of Time Period

Time period is the minimum time period unit of Access Options. Whole system can be defined with maximum 50 time periods. And 7 time regions (i.e. one week) can be set in each time period. Each time region is effective time period in 24 hours of a day. Each user can own maximum 3 time periods. Relationships among these three time periods are “OR”. It is effective as long as the time to verify that can meet one of these three time periods. Each time period format of time period is HH:MM-HH:MM and its format is according to 24-hour mode and accurate to minute. This option can only be configured by the User Administrator or the Super Administrator.

End-time less than start-time (E.g. 23:57-23:56) represents all-day forbidden. End-time larger than start-time (E.g. 00:00- 23:59) takes effective in this range.

Effective time period for user to unlock: all-day open (00:00-23:59) or end-time larger than start-time in time period.

**Note: System defaults that time period of serial number 1 is all-day open, the new register user belong to the group1 and own the serial number1 time period, so the new registered user default can unlock door).**

The setting procedure of time period is follow. .

- 1 Enter “Define TZ” and screen displays as follows

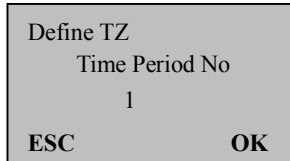

Press “OK” to enter setting of time period 1 and screen displays as

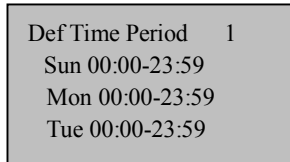

follows



Definition of time period 1 above is all-day open, i.e. factory default status.

- 2 For example: Time period can be redefined,

E.g.: Definition of time period 1 is:

Saturday and Sunday are break, and don't allow to enter.  
Working time of Monday to Friday is allowed to enter.  
Working hour: 08:30-18:00

Setting is as follows

Def Time Period	1
Sun	23:57-23:56
Mon	08:30-18:00
Tue	08:30-18:00
Wed	08:30-18:00
Tue	08:30-18:00
Fri	08:30-18:00
Sat	23:57-23:56

On analogy of this, multi time periods can be defined according to practical requirements. Whole system can define maximum 50 time periods.

### 5.5.3.2 Definition of Grouping Function

An Access Group allows for users to be given standard access for the workplace. Different departments may have different access privileges and some corporation's employees who are on shift duties, and may need different access levels for each shift, depending upon their time of entry and exit from the workplace. To fasten the procedure of giving access privileges, it can now be done for groups, instead of individuals to simplify the process and give it

more transparency.

Grouping function can divide users into group, and can also combine different groups into different unlocking combinations; the grouping function can combine many unlocking combinations. System ability to define total 5 groups: group 1, group 2, group 3, group 4 and group 5. New registered user by default belongs to group 1, and first uses time period of group, but the user can be allocated into other group, selected serial number of Time period already being set in group Time group Time, after user resets the belonged group, the user uses default time period of correlative group. So default time period of each group should be defined first.

**Note: time period of system defaults that group 1 selects serial number “1” of time period. (E.g. new registered user default can unlock door)**

The setting procedure of Access Group is follow.

- 1) Enter “GRP 1 TZ Define “ and screen displays as follows:
- 2) Press **OK** to enter.

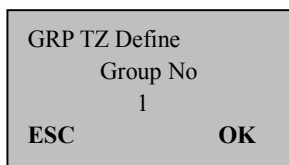

- 3) There are 3 time periods in GRP TZ Define. Relationships

among these 3 time periods are “OR”.

GRP 1Delt TZ	
TZ1	1
TZ2	8
TZ3	40

- 4) Group 1 is effective in time periods of 1, 8 and 40, and can also select other defined time periods

Enter “GRP 2 Dflt TZ “ and screen displays as follows

GRP TZ Define	
Group No	
2	
<b>ESC</b>	<b>OK</b>

- 5) Setting of time period of group 2

- 6) Press OK to enter.

Group 2 is effective in time periods of 2, 10 and 36, and can also select other defined time periods.

GRP Dflt TZ	
TZ1	2
TZ2	10
TZ3	36

- 7) On the analogy of this, time periods of each group can be defined according to actual requirements. Whole system can define time periods of maximum 5 groups.

### 5.5.3.3 User Acc Opts

User Access Options is to process correlative setting according to user's requirements which include: To belong to grouping setting, use group time period and user time period.

Enter this menu to check certain user's Access Options status.

- n Grouping:** divides registered users into several groups, is easy and convenient to manage.
- n Use GRP TZs (Use group time period):** whether the user uses default time period of belonged group.
- n User time period:** is user to set user's unlocking time and select serial number of time period already being set.

#### **Note:**

Relationships between use group time period and user time period.

**Yes** and **No** in “**Use Group Time period**” only have impact

on the following **user time period**:

If **use group time period** is “**Yes**”, then user time period will automatically be assigned the value of serial number of time period of belonged group (group time period should be set in advance).

If **User Time period** is changed, then **use group time period** automatically change to “**No**”.

The following example is to distribute user 00001 and 00002 to group 1 and group

- A. Enter option interface of serial number 00001, and screen displays as follows

User Acc Opts	
Enroll ID	00001
<b>ESC</b>	<b>OK</b>

Press “**OK**” to enter Option menu of **use group time period**. Press “**UP**” and “**DOWN**” keys and select “**Yes**”. User 00001 is effective in time periods of 1, 8 and 48 “**Allow Group**” is set as Yes, we suppose that the Group 1 verifying type is password( ability to set it under

User 00001Opt	
Belong to GRP	1
Use GRP TZs	Y
TZ1	1

**GroupVerType of Access Control Option)**Screen displays as follows

TZ2	8
TZ3	40
Type	FP
GroupVerType	Y

User of serial number 00001

1 User's belonged grouping is "1", it uses time period of group 1 (serial number of user time period is serial number of group time period)

User use GroupVer Type, In spite of user has chosen any individual verifying type; all take only Group verifying type as the criterion.

B. Enter setting interface of serial number 00002, and screen

User Acc Opts	
Enroll No	00002
<b>ESC</b>	<b>OK</b>

displays as follows

Press **OK** to enter

If serial number of user time period is 1 or 20, then **use group time period** automatically change to “**No**”

GroupVerType is set as NO so user use type ( individual Verifying

User 00002Opt	
Belong to GRP	2
User GRP TZs	N
TZ1	1

type)as following figure.

TZ 2	20
TZ3	
Type	FP
GroupVer type	N

User of serial number 00002

1 User’s belonged grouping is “2”, it uses user time period and does not use group time period, i.E. it is effective in time periods of 1 and 20

When user wants to use group time period, then select “**Yes**”. In user time period, serial number of group time period will be automatically assigned the value of serial number of group time period. Contrariwise, if user wants to use user time period, just directly modify the serial number in user time period and **use group time period** will automatically change to “**No**”.

2 user use individual Verifying type, namely use fingerprint verifying type

#### **5.5.3.4 Access Comb**

Unlocking combination is the direct representation of controlling unlocking. E.g., if user wants that all registered users cannot unlock, then the user can set all 10 unlocking combinations to null.

Unlocking combination definition is to define different unlocking combinations, and each combination is composed of different groups. Unlocking combination directly uses group number and does not consider user verification sequence between each group. For example “123” represents group 1, group 2, group 3 and at least one user in each group congregates and passes verification together, then door can be unlocked. “4” represents that after individual user in group 4 passes verification, and then door can be unlocked. System can simultaneously define maximum 10 unlocking combinations. It is required that only one of them passes verification.

#### **Note:**

**Unlocking combination of system initial default setting is “1” (i.e. new registered user default can unlock door).**

The setting procedure of Access Combination is follow

Press “MENU” and enter main interface.

Select “Options” and press “OK” to enter setting menu.

Select “Access Options” and press OK to enter menu.

Select “Unlocking Combination Definition” to enter “Unlocking Combination” and screen displays as follows:

Access Comb	
Comb 1	1
Comb 2	
Comb 3	
Comb 4	
Comb 5	
Comb 6	
Comb 7	
Comb 8	
Comb 9	
Comb 10	

When do not process setting yet (i.e. factory default status), system defaults that group 1 is unlocking combination 1 and others are null.

If do not want to allow all users to unlock door, then set 10 unlocking combination all to null.

If only want to allow some groups to unlock door together, then set these groups in unlocking combination definition.

For example

Access Comb	
Comb1	
123	
Comb	2
.	
Comb 4	45
Comb 5	15
Comb 6	
Comb 7	
Comb 8	
Comb 9	
Comb 10	

From above combination setting, it can be seen that:

123 is a combination.

4 is a combination.

24 is a combination.

45 is a combination.

15 is a combination

**Combination 1:** when personnel of group 1, group 2 and group 3 are all on the scene and the time period is effective in which at least one user in each group passes verification together, then door can be unlocked.

**Combination 2:** only one of personnel belonged to group 4 is on the scene, then door can be unlocked.

**Combination 3:** when personnel of group 2 and group 4 are all on

the scene and the time period is effective in which at least one user in each group passes verification together, then door can be unlocked.

**Combination 4:** when personnel of group 4 and group 5 are all on the scene and the time period is effective in which at least one user in each group pass verification together, then door can be unlocked.

**Combination 5:** when personnel of group 1 and group 5 are all on the scene and the time period is effective in which at least one user in each group pass verification together, then door can be unlocked.

## **Note:**

### **Time periods that cannot pass verification**

- 2 User time period does not select serial number of time period.**
- 2 Group time period does not select serial number of time period.**
- 2 Time in which user passes verification does not include any time period that is set by user.**
- 2 Time period is defined as forbidden.**

**If time period that user sets is the time period that cannot pass verification.**

- 2 When meet combination 2 above, user who displays prompt of “Invalid Time period Access” cannot**

**unlock door, but can record attendance. (If there is user in group 4 who can meet unlocking condition, then combination 2 can unlock door)**

**<sup>2</sup> When meet combination 1, 3, 4, and 5 above, user who displays prompt of “Invalid Time period Access” cannot unlock door, but can record attendance**

2 For example: one bank treasury requires that 3 people are all on the scene to open the door of treasury. Detailed settings are as follows:

These 3 people belong to group 2, group 4 and group 5 respectively, and have the right to unlock door within the same time period. Select “Group 1” and press “OK” to enter edit status. Press digit keys to enter 245. Then press ESC to exit and save setting interface.

**Note: When combination 245 is defined, then user cannot define 24, 25, and 45 as combination.**

### **5.5.3.5 Lock**

The Lock means the duration of lock drive, System requires to set fingerprint machine to control the time how long to open electronic lock, setting to “0” is close. Close lock control function. One quantity unit is 20ms; maximum value can be set as 254, i.e. 5.08s. Select this item and press “OK” to enter Options. Then press digit keys to input corresponding digits. Finally press “ESC” to exit and save setting.

### 5.5.3.6 DSen. Delay

**DSen. Delay** : Some segment time which begin after open door just begin alarm

Press “MENU” enter main interface

Select “Options” Press “OK” to enter

Select “Acc Opts” Press “OK”to enter menu

Press UP or Down to enter select DSen. Delay display as follows

Access Option		▲
Access Comb		▼
Lock	150	
▶ Dsen Delay	10	

Press **OK** select number Press Up or Down key to modify DSen. Delay

### 5.5.3.7 DSen. Mode

**DSen. Modes include** three **No, NC, None** **No:** No use door

sensor; **NC**: When the door is open, the lock is open; **none**: When the door is closed, the lock is closed.

Press “MENU” enter main interface

Select “Options” press “OK” enter menu

Select “Acc Opts” press “ok” enter menu

Press Up or Down key enter ,select DSen.Mode display as follows

Access Option	▲
Dsen delay	10
▶ Dsen mode	
NO	

Press **OK** select option press Up or Down key to change the condition of DSen. Mode.

## 5.5.4 Dress Options

Press “MENU”key to enter main interface

Choose “Option” Press”OK”key to enter the Option Menu

Select “Access Option” Press OK to enter Menu

Press “▲” and “▼” to scroll up or down the screen to select the option.

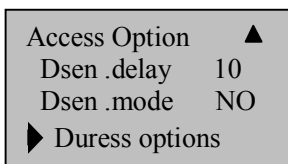

The Duress alarm option includes that duress fingerprint management. Seeking help key, alarm by 1:1 validate, alarm by 1: N validate. Alarm by verifying password and alarm delay etc.

### 5.5.4.1 The duress fingerprint management

Use newly to enroll specialties fingerprint or define an enrolled fingerprint as the duress fingerprint, the system will trigger an alarm signal when this fingerprint has been authenticate through fair and foul.

Enter the duress alarm option, Press “▲” and “▼”to scroll up or

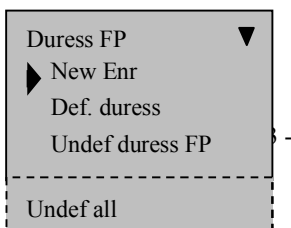

down the screen to select the “Duress F P”, Press “ok” to enter

**Newly enroll duress fingerprint (New Enr.)** Enroll new fingerprint as the duress fingerprint.

**Define the duress fingerprint (Def.duress)** Change the enrolled fingerprint to the duress fingerprint.

**Cancel the duress fingerprint (Undef duress FP):** Cancel the single duress fingerprint.

**Cancel all( Undef all)** Cancel all duress fingerprints

### 5.5.4.2 Seeking help by key

Enter the duress alarm option, press up or down key to scroll, choose the “help key”

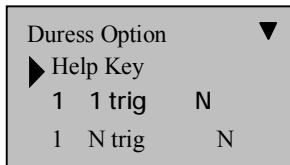

If the seeking helps by key (help key) option is defined as “y”. Keep hold to press the “▼” key (more than 3 sec.), the machine will trigger appeal signal, keep hold to press “▼”key (no more than 3 sec.) and place finger or input ID No. After the authentication is positive, the system will trigger the alarm signal. If the help key option is set as “N”, well then it is invalid when the “▼”key is pressed.

### 5.5.4.3 the mode of validation alarm

The fingerprint machine fully supports three verification modes:

**1:1 match, 1: N match, Password authentication**, and here you can choose one or other several verification way for the duress alarm, when a user uses the option is defined as Yes, the system will produce alarm signal

Duress Option ▲		
Duress FP		
Help Key		
▶	1 1 Tria	N
	1 n Trig	N
	PWD Trig	N
	Alarm delay	10

### 5.5.4.4 Alarmdelay

Defining automated alarm time When the duress alarm happen and the system do not directly trigger alarm signal immediately, but can define a period time until automatically trigger alarm signal (0-255sec.)

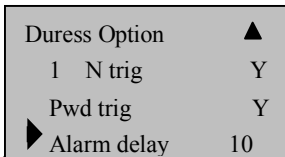

### 5.5.5 How to set the number of failure to verify

This option is a optional item, it only exist access control machine, if times of user failure to verify equal to the value , the fingerprint machine will send alarm signal, the set step is follow.

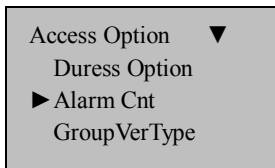

- n Press (MENU) to enter main interface.
- n Select “option” then press “OK”, Press “▲” and “▼”to scroll up or down the screen to select **Alarm Cnt**.
- n Press OK and Input the value you want, the system provides with 0-9 digit to select, 0 means this function is invalid.

n Press **OK** key. And exit

## 5.5.6 Group Verification

This option also is an optional item. It only is owned by some fingerprint access control machine, if this option is set as Y(yes), the fingerprint machine will able to perform Multi-combination verification, its set step is follow.

Press “OK”, Press “▲” and “▼”to scroll up or down the screen to select Group VerType, show as follow picture.

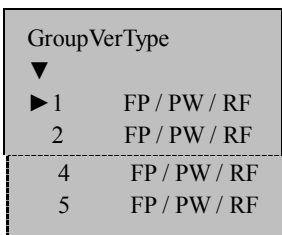

GroupVerType	
▼	
▶ 1	FP / PW / RF
2	FP / PW / RF
4	FP / PW / RF
5	FP / PW / RF

Press “▲/▼” key to choose group, press OK to local at this line, Press “▲/▼” key to select verifying type of this group, after completing. Press OK to confirm, press ESC to exit, the system will prompt whether save revised item, press OK to save it.

## 5.6 Auto Test

Access auto test, the following message appears

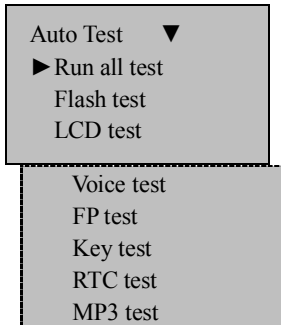

In the option, you can run system machine test. When the machine broken down, it can analyze the cause of the machine's fault and the machines were quickly and easily maintained. It tests the **Memory, LCD, and Sound, Fingerprint sensor, keypad and clock**. In the course of test, you should guarantee the stability of the power. Otherwise, the system's hardware was probably damaged; especially it runs the memory test.

## 6.How to Manage USB Flash Disk

Choose USB flash disk management in the menu; press [OK], the

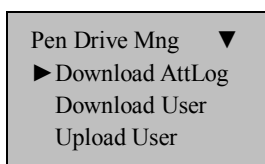

following appears

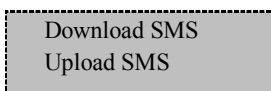

The USB flash disk can be used to download the attendance data, and download and upload employee data SMS.

### 6.1 Download the attendance data

- 1 Plug the USB flash in the USB slot
- 2 Press the Menu button to enter the “USB flash disk management” menu , Press “▲” and “▼”to scroll up or down the screen to select the “Download AttLog”,

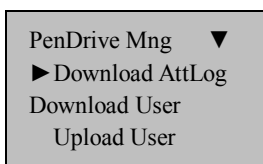

3 Press “ok” to go on downloading data, after operation finish, this interface show as follow.

4) Press “ESC” key to exit initial interface Take out U flash disk

The files X\_attlog.dat (attendance log), X\_oplog .dat (management log), and X\_user will be saved in the USB flash disk(X is a symbol

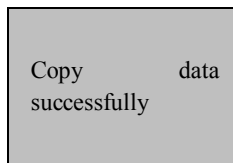

of machine No.

**Note: It will show data copy successful when operation is finish. If it indicates No USB Disk or Please insert the USB Disk and make an examination.**

## 6.2 Download Staff Data

The operation is similar with that of the attendance data, the file of User data (user data) and Template. data fingerprint template will be saved in the USB flash disk. These files shall be uploaded and downloaded at same time; it will show data copy successful when operation is finish. If it indicates NO USB Disk or Please insert the USB Disk and make an examination.

## 6.3 Upload Staff Data

Select Pendrive Management. Press “▲” and “▼”to scroll up or down to select the “Upload Staff Data”, Press “OK” key to perform this operation, the two file, Userdat. Template, in the U flash disk will be uploaded to fingerprint machine at same time.

## 6.4 Download SMS

The operation is similar with that of the attendance data, enter **Pendrive Management**, Press “▲” and “▼”to scroll up or down to select the “Download SMS”, Press OK key to perform this operation, after finishing, show whether the operation is successful.

## 6.5 Upload SMS

After set Short Message where is under the software, “External program”-> “Short message”. Select “External program”-> “U flash disk management”-> “Export Short Message”-> “Export SMS to U flash disk”, after export SMS successfully. Plug the U flash disk into fingerprint machine. Select item from fingerprint machine via “Menu”->“Pendrive Mng” -> “Upload SMS”. Send the customized SMS to the fingerprint machine.

**Note** These functions are only available to the fingerprint machine which own USB flash disk function. If you want to use these

**functions, please contact our market supporter or salesman.**

## 7. System Information

Through system Information you can view machine all information

Sys Info	▼
▶ User Cnt	206
FP Cnt	173
Att Log	8046

Access [Menu] to Sys Info, press [OK], the following appears

Admin Cnt	2
Pwd User	30
Super Logs	263
Free Space Inf	
Dev Info	

The follow table illustrates what LCD showing item means

- n **User Cnt:** The total amount of use has been enrolled.
- n **FP Cnt:** The total amount of fingerprint.
- n **Att log :** The record of attendance which have been stored in the system
- n **Admin Cnt:** The total amount of administer who has been

registered in the system.

- n **Pwd User:** The total amount of user who use password to achieve authentication.
- n **Free space info:** the remainder log capacity, how long reach set numerical value.
- n **Dev Info:** About this machine information.
- n **Firmware Ver:** The version of the machine firmware.
- n **Alg version:** The version of the fingerprint identification algorithm.
- n **Serial Num:** Manufacture serial number.
- n **Manu time:** Manufacture time.
- n **S Logs:** Supper administrator's logs.
- n **Vendor:** This machine's manufacture
- n **Machine Name:** This machine's name.

## 8.Relieve Alarm

This function only is provided by fingerprint access control machine. In following situation this function is availability.

User makes a mistake, who use duress finger to verify, the machine send an alarm, have to stop alarm.

During the installation and maintenance, occur the accident cause to the anti-dismantle button loose, the fingerprint machine will produce alarm to prompt the machine has been dismantled, at this time, please fix the machine's anti-dismantle, use the relieving alarm function to stop alarm. The operation step is follow:

Press (MENU) to enter main interface.

- choose “Relieve”.
- scroll “▼” and “▲” up or down to set the value you want.

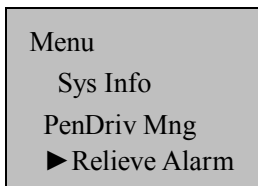

## 9.View T&A Records

**This fingerprint machine does not provide with this option that follows that standard approved for use with this machine if you need this function; Please contact our market supporter or salesman.**

---

This machine gains a new function to inquire the record, which provides a capability to query individual or all Time & Attendance record.

### **1 The way of inquiring attendance record**

This machine provide user with two inquiring way

- I** Enter menu->view attendance record- input a registered No. that you want to inquire press [OK] key search staff's attendance record whose PIN is appointed. If do not input staff's No. keep the screen displaying as "00000", the inquiring function will display crew's all attendance record

- I After checked a staff, before the interface will restore to the initial attendance interface (time display by big font), press Menu key to inquire this staff attendance record.

For example Query T&A record which Attendance ID is 00014.

```
00014 2006-5 1/23
27 08:30 12:10 13:20
18:08
26 08:46 12:15 13:25
18:23 18:55 22:20
25 08:53 12:07 13:19
18:23
```

Query all attendance record interface

```
1/380
00001 05-27 18:46:21I
00012 05-27 18:32:09I
00217 05-27 18:30:52I
00031 05-27 18:29:01I
00016 05-27 18:27:55I
00029 05-27 18:22:08I
```

## 2 The way of brows attendance record

The attendance record serration according to record time from newly to old, while brows the record, ability to use following key to

View T&A

operation

Key	Function explain
▲	previous display content
▼	Next display content
1	move a rank to left for displaying content
3	move a rank to right for displaying content
OK	restore right and left displaying position to initial value
2	move a line up for displaying content
5	move a line down for displaying content
4	<p>Switch displaying mode of the compact forms/complete forms record.</p> <p>For example the right figure is the compact form of “the completely attendance recording” and the complete form alternative effect figure.</p> <p>1 Compact form: it is designed to the record displaying form that can demonstrate enough</p>

1/380

00001 05-27 18:46:21I  
00012 05-27 18:32:09I  
00217 05-27 18:30:52I  
00031 05-27 18:29:01I  
00016 05-27 18:27:55I  
00029 05-27 18:22:08I

The compact form

1/380

00001 27 18:46IF  
00012 27 18:32IF  
00217 27 18:30IF  
00031 27 18:29IF  
00016 27 18:27IF  
00029 27 18:22IF

The completes form

	<p>many information on the LCD screen.</p> <p>I completes the form: it is designed to record demonstration form that can demonstrate the integrity field value</p>	
6	<p>Alter the fonts/small font's record displaying mode, like as the right figure, take "individual attendance interface" as an example, the effect figure is to alter small font and big font.</p>	<div style="border: 1px solid black; padding: 5px; margin-bottom: 10px;"> <p>00014 2006-5 1/23  27 08:30 12:10 13:20  18:08  26 08:46 12:15 13:25  18:23 18:55 22:20  25 08:53 12:07 13:19  18:23</p> </div> <p style="text-align: center;">Small font</p> <div style="border: 1px solid black; padding: 5px;"> <p>27 08:30 12:10  13:20 18:08  26 08:46 12:15  13:25 18:23  18:55 22:20</p> </div> <p style="text-align: center;">Big font</p>
9	Up to the minute record	
0	The oldest record	

### 3 View records and print out

View T&A

When you view record on the fingerprint machine, you can press OK key to print out record content the screen display currently, through the super terminal this export may be viewed.

# 10.Maintained

**Notice: Do not attempt to service the machine yourself unless you are a trained service technician. Always follow instruction closely**

---

## Cleaning

From time to time, the surface of optical sensor, the keypad and display window will be required to clean. Since its working environments differ, it is not possible to define when cleaning should be performed. Following is guide

Item	Cleaning Frequency
Keypad and display window	Cleaning when visibly dirty and hard to read. See cleaning the keypad and display below.
Optical sensor	Do not over clean. The sensor is designed to work under greasy or dirty conditions.
	However, do clean if the sensor is affected or people are reporting deteriorating performance. See cleaning the Optical Sensor below.

## Cleaning the Keypad and Display

To clean the keypad and display, use the same cleaning products as for the soft cloth, and wipe dry.

### **Cleaning the Optical Sensor**

Clean the optical sensor as follows:

- (1) If dusty or gritty, first blow on surface of the sensor to clean off any loose particles.
- (2) Use the adhesive tape to clean surface of optical sensor.
- (3) Using a non-abrasive and soft, dry clothe. Be careful not to scratch the surface of the sensor. If there are lint particles here in the sensor surface, below them off when the sensor is dry.

### **Caution:**

**Do not use any other cleaner otherwise the sensor maybe occur damaged.**

**Cleaning solvent that contain alcohol or other strong substance may discolor or crack the fingerprint machine cabinet.**

# 11. Troubleshooting

**1. Q: Some users' fingerprints sometimes can't be verified.**

**A: Cause:** the follow circs result in staff are failure to use fingerprint for punching in. The fingerprint quality is poor.

- 1) Some fingers the fingerprint is smooth by rub-down;
- 2) On the finger the drape are too many, frequently change;
- 3) On the finger sheds skin seriously

**Measure:** You'd better select fine fingerprint (less crinkle, no desquamation, clear image) when enroll fingerprint, make your finger touch fingerprint sensor with larger area, a comparable test should be made after enrollment, we suggest you enroll more fingerprints. By the way our machine supports 1:1 match method and password identified function, you could choose one of them.

**2. Q: When the fingerprint machines fail to communicate, which the reason cause it?**

**A:** The possible reason:

- 1) The communication port configuration is not correct; elect to connect communication port is not the COM port which is actually used.
- 2) Baud rate of between the computer communication port and

the fingerprint machine setting value are different.

3) The fingerprint machine has failed to connect with the power source or the computer;

4) The fingerprint machine has connected but not starting up.

5) The serial number of linked terminal is not correct.

6) Data line or converter fails to communicate.

7) The computer COM port breaks down.

**3. Q: after the fingerprint machine power on, the LCD show incompletely, only one half, sometimes jumbled, what happen, how should solve?**

**A:** The possible reason is

1) Motherboard is bad;

2) Caused by Liquid crystal internal matter. By now need to contact supplier, and return it to the service.

**4. Q: How to clear the administrator of the attendance machine**

**A** 1).Can utilize the standalone communication program of attendance machine between computer after it's successful enter attendance machine management page click on the 'cancel administrator' button able to clean attendance machine administrator after to break out connection then can enter attendance machine menu style.

2).Call technical support from a telephone near or at the fingerprint machine so that technical support can assist you to solve the problem with any necessary procedure.

**5. Q: When fingerprint machine go on connection communication the sound “ding, ding” appears, what the cry reason is?**

**A: 1)** when Uses the RS-232 communication, maybe the computer baud rate is inconsistent with the fingerprint machine baud rate.

2) If uses the RS-485 communication, then possibly was two lines of the converter counter- join, or sticks in.

**6. Q: After machine power is on, LCD display always shows “Please try again”**

**A: Cause:** For long time used, surface of fingerprint sensor

becomes dirty, or there are some scratches on it, the machine takes it as a fingerprint and does verification,

Fingerprint connection cable of fingerprint sensor is loosed. Chip-on-board is broken down.

**Measure:** under such situation you can use scotch tape to

exhibit the dirt. Need to contact supplier and ask for repair.

**7. Q: When the terminal management carries on the operation,**

**download fingerprint and the password data all successfully, but when read in the checking attendance record the system actually prompts the failure or false occur, asked how solves?**

**A:** This kind of situation is possible relative with the data line, either converter, computer COM port, by now you are allowed to reduce fingerprint and the computer communication baud rate, like as, set it as 19200 or 9,600, try again to read in.

# Appendix

**The function in the appendix introduced is additional, if needs the machine with these functions, please consult our commercial representative or the pre-sale technical supporter.**

---

## U flash disk management

U flash disk (to be named the U disk) is a substitute of floppy disk the people have commonly used. It is a the miniature, high capacity memory ,mobileable product which is no the physical driver available, and with USB port, may through the USB port connect with the computer , realize the plug and play, it own smart, light and lively, reliable, easy using characteristic and so on..

### The superiority to using U disk

#### 1, USB Master

Fingerprint machine will may be uesd as USB Master to exchange data with external U-disk.

The data transmission speed is quick, the traditional fingerprint machine only supports the RS232, RS485 or Ethernet way data

transmission, when as a result of physical condition limit, data quantity big, and the data transmission cost quite long time. But the USB data transmission is more quick than the former any transmission mode, may complete downloading data by U disk in a short period of time, like this greatly enhances the efficiency.

The operational steps of USB Master equipment, please refer to the book "7, U flash disk -management" detailed briefing.

Please refer to the book "5.3 communications settings." Detailed.

## 2, USB Client

Fingerprint machine will be as removable storage devices and fingerprint machine data will transfer to a PC via connectaly USB cable.

When the fingerprint machine as a USB Client, the fingerprint machine communication settings menu will have USB communications options,

**Note:** When you use USB Client fingerprint machine and PC connectivity, PC, the relevant driver must be installed.

### **How to use the U disk to transmit data?**

The fingerprint machine with the USB slot all are allowed to use the U flash disk to download and upload date. About U flash disk

management see (this manual chapter 6).

## State key

The Time& Attendance machine under using, the different state corresponds the different event, according to different situation a job state will be divided into: clock in, clock out, overtime check-in, overtime check out, going out, return in and so on, but Access Control machine in out condition is divided into “comes in” and “goes out” the different situation:

On some machine keyboards there are 6 conditions keys to set the current condition. you may press “ ” and “▼” turn the page to choose condition. But these ways need manually set, namely some condition needs to be used according to corresponding state button. In order to reduce the manual operation, we also could specially develop time state selection function, upon arrival the set time by user, the machine could automatically switch current condition and show in the initial interface. If needs to custom-made the machine with the time alteration function, please contact us specially to custom-made, for the detail step of operation see 5.2.2

## Time Ring

In many factories , ringing apply to broadcast message to inform

employee their duty are on or off, the traditional way is to ring bell by manual or special electron machine, we have already embedded the time ring module into the fingerprint T& A system, you may benefit from this low cost and convenience management. There are more two options that is Bell schedule and Bell duration in the fingerprint machine time bell ring provide with. The system total has eight Bell schedule to set, according to actual need you may set time bell, when the time arrive at the appointed time, the fingerprint machine will automatically ring bell, the duration of ringing achieve assigned hour, the ringing will stop automatically.

There are two way to ring bell

1. Send sound from the speaker of fingerprint machine.
2. Connect the electrical bell to the fingerprint machine, when arrive the appoint time, the fingerprint machine will send signal to trigger relay

For more detail see (instruction to time ring).

## **External Fingerprint Sensor**

This is a unique function of the fingerprint machine with USB Port, plug the fingerprint sensor into the USB slot, enter the menu->Option->Advance Option -> external fingerprint sensor, and set the “External Sensor” item as “Y”. Now external sensor and

internal sensor are owned by fingerprint biometric may be used together.

For application of T&A system, it can influence crowd of centralized check on attendance, eliminate stagnant state,

For application of Access Control System, the external fingerprint sensor can be located in external door; the main machine is installed in inside, this configure are not only controlled by internal and external, but also ensure the main machine security and safety.

**Note:**

**1) After connecting fingerprint sensor with fingerprint machine, be sure to restart the fingerprint machine, so the external fingerprint sensor take effect.**

**2 The external fingerprint sensor is not able to be used until write SDK permission in.**

## **Modem Function**

In order to achieve PC and fingerprint machine communication through remote connection without network area, some type machine support using PPP connection, PPP connection is a point to point connection through a line, PC does not dial up and connect network through modem until the fingerprint machine connect with

Modem and telephone, then dial up, then successfully achieve connection network.

**[Steps]**

1, please use the marked "Modem" cable that standard provide, establish link between the fingerprint machine and external modem (Modem). Respectively power up the fingerprint machine and Modem, and then access to telephone Modem.

2, entered the fingerprint machine menu, option -> Communications Settings -> set external modem, set this option to "Yes", save it, and then restart the fingerprint machine, be sure this function take effect.

3, set a dial-up connection, follow through Windows XP an example to show a dial-up connection, the process of the setting :

1) access to the connection to, the local area connection appear, as shown below

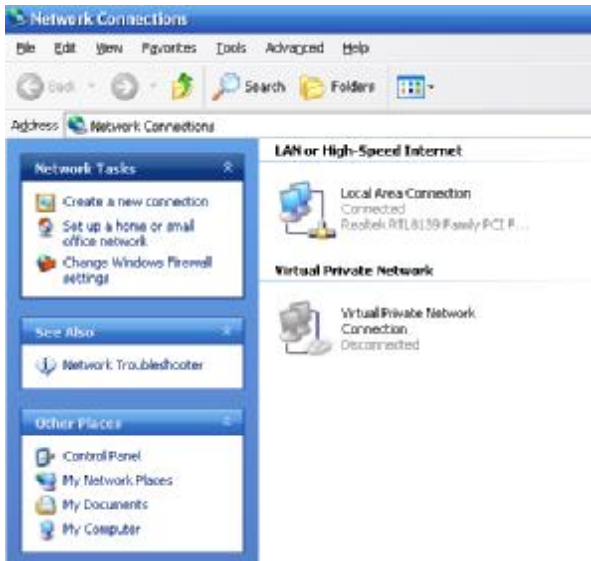

2) Choice in the network, "to create a new connection," a Connection Wizard.

3) Click on the "next" in the interface as follows:

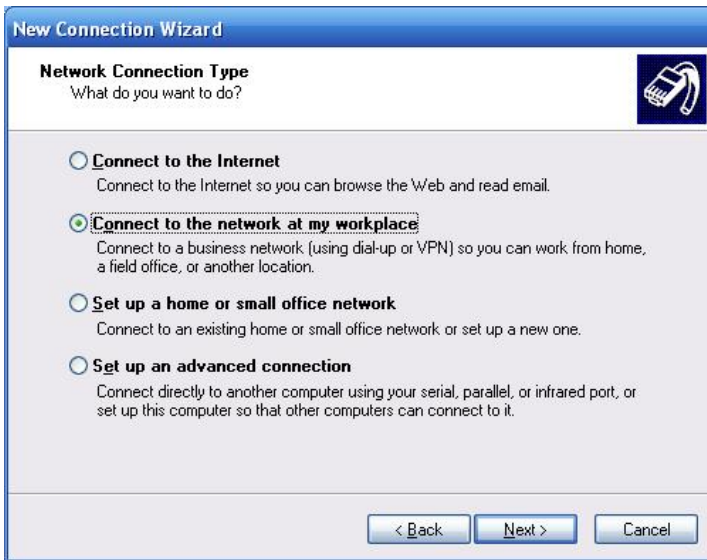

4) Selecte the marked item, and then click the "next " in the interface:

5) Select a dial-up connection, then click the "next ."

6) import company name, then click the "next " in the interface as follows:

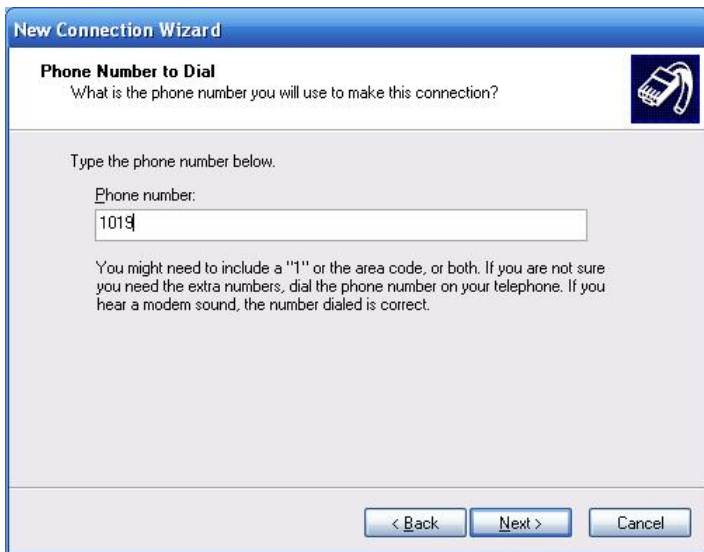

7) In a telephone number column, fill the number of telephone that modem connected with, there are several situations:

I. via the internal extensions call the extension, directly input the number of extensions that modem connect to, such as the above figure the 1019 is the numbers of extension.

use the external telephone to call internal phone, the need to enter switchboard number, then enter the extension number, divided it with a comma, every comma that stopped for 3 seconds, if necessary, can add a few commas. it is same with above switchboard telephone number, before the need to add the area

code of the city.

l.iii. Directly dial-up, directly import the telephone numbers, the same attention to the area code issue.

Statistics generally is 0 or 9, then enter the telephone number to call, the middle with a comma, for example, enter "9,02150814442" on the outside can be allocated.

8) input has been completed, click the "next step" in the interface as follows:

9) connection established after the completion of the establishment of our new double-click the connection, there are interface:

10) imported user name and password are ppp , click "dial-up", begin to establish a connection, a successful connection, the fingerprint machine default IP address is: 192.168.1.100.

11) Open attendance software, equipment will be adapted to the IP address of 192.168.1.100,

12) click the "connect" button, after the success of connected machines (shown below), we can upload or download data for the work.

## **Modem notice**

1 Please use the cable which marks “ Modem Cable” to connect with Modem and FINGERPRINT MACHINE.(We supply Modem cable).

2 you should use FINGERPRINT MACHINE controller to supply the power for Modem once you used it.

3 before connection Modem please set “Extern Modem” value as “Y”  
**(Menu->Options->Comm. Opt->ExternMODEM)** on FINGERPRINT MACHINE menu.

4 When use Modem, RS232, RS485 for FINGERPRINT MACHINE are forbidden. Once Extern Modem” value is “N” (non use of Modem), RS232, RS485 is working.

5 PPP Server has already been embedded in FINGERPRINT MACHINE, please use Widows “Dial up” etc PPP user terminal program to connect with FINGERPRINT MACHINE, the default user name is ppp, as well as the password.. After setting PPP communication, default IP address is 192.168.1.133, user terminal IP address is 192.168.1.100.

6 Using standard Modem connection

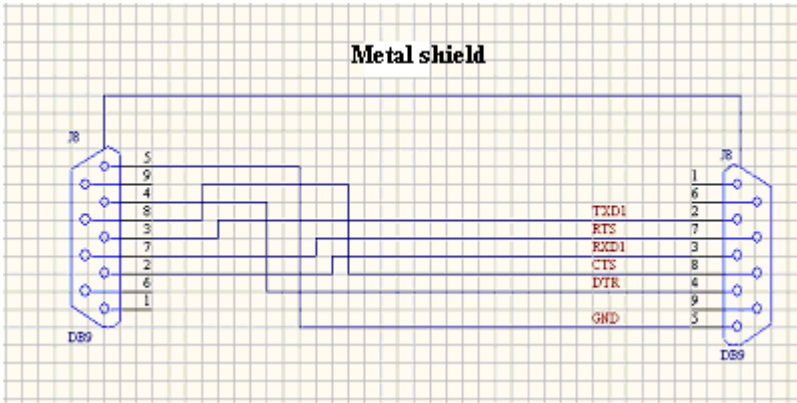

Figure: Modem Cable

## About GPRS

General Packet Radio Services (GPRS) is a packet-based wireless communication service that promises data rates from 56 up to 114 Kbps and continuous connection to the Internet for mobile phone and computer users. The higher data rates allow users to take part in video conferences and interact with multimedia Web sites and similar applications using mobile handheld devices as well as notebook computers. GPRS is based on Global System for Mobile (GSM) communication and complements existing services such circuit-switched cellular phone connections and the Short Message Service (SMS).

We fingerprint machine has also realized the GPRS function. GPRS modules can be built-in fingerprint machine , also can be an external GPRS module to achieve the GPRS systems for data transfer.

How to operate GPRS fingerprint machine, please see related functional specification.

## **WIFI function**

Wi-Fi (short for "wireless fidelity") is a term for certain types of wireless local area network (WLAN) that use specifications in the 802.11 family. The term Wi-Fi was created by an organization called the Wi-Fi Alliance, which oversees tests that certify product interoperability. A product that passes the alliance tests is given the label "Wi-Fi certified" (a registered trademark).

Originally, Wi-Fi certification was applicable only to products using the 802.11b standard. Today, Wi-Fi can apply to products that use any 802.11 standard. The 802.11 specifications are part of an evolving set of wireless network standards known as the 802.11 family. The particular specification under which a Wi-Fi network operates is called the "flavor" of the network. Wi-Fi has gained acceptance in many businesses, agencies, schools, and homes as an alternative to a wired LAN. Many airports, hotels, and fast-food facilities offer public access to Wi-Fi networks. These locations are known as hot spots. Many charge a daily or hourly rate for access,

but some are free. An interconnected area of hot spots and network access points is known as a hot zone.

Unless adequately protected, a Wi-Fi network can be susceptible to access by unauthorized users who use the access as a free Internet connection. The activity of locating and exploiting security-exposed wireless LANs is called war driving. An identifying iconography, called war chalking, has evolved. Any entity that has a wireless LAN should use security safeguards such as the Wired Equivalent Privacy (WEP) encryption standard, the more recent Wi-Fi Protected Access (WPA), Internet Protocol Security (IPsec), or a virtual private network (VPN).

Its main features are: high speed, high reliability, in the opening of region, communications distance of up to 305 meters, in a closed region, communication distance is 76 m to 122 m, convenient , Network costs are lower than the existing wired Ethernet.

We fingerprint machine has also realized the WIFI function. WIFI modules can be built-in fingerprint machine , can be an external module WIFI to achieve through WIFI wireless data transmission.

For detail , please see related functional specification of WIFI fingerprint machine

## Query function

The fingerprint machines which support query function realize to view attendance record for personal or all staffs. So provide with a solution that relieves trouble that user unknown the attendance result until complete to install T& A software, connect with machine, and download attendance record. The query function provides staff with convenience to know attendance record by him.

This machine not only ability to view persona's attendance record, but also support to query all staff's record.

For detail step, see chapter 9, View T&A record.

## Print Function

### [Explain]

this function is designed for a serial port printer only, the parallel printer is unavailable. the content that attempt to print output via RS232 , after each user is verified the result will be sended out through serial port. If fingerprint machine connect with the printer the result can be printed directly, can also use the Super Terminal to wiew the output content.

Fingerprint machine connect with printer	Fingerprint machine printer 2 TXD <-----> 3 RXD 3 RXD <-----> 2 TXD 5 GND <-----> 7 FG
---	---

**[Connection]**

Schematic diagram

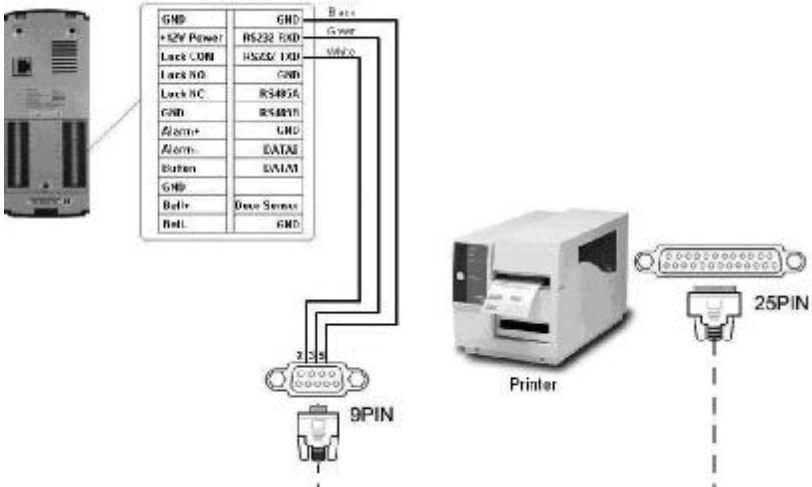

**[Instructions]**

In the fingerprint machine menu, the menu -> Option -> System Option -> Advanced Settings -> ~~Print-format~~. There are total 10 kinds of formats available.

For example: San punched the card at 13:24:55 on November 1, 2007, there are different print formats to select, shown as below:

Version 1

00001 07-11-01 13:24:55

Version 2

User ID: 00001

Date Time Check-In

07-11-01 13:24:55

Version 3

00001 San 07-11-01 13:24:55

Version 4 - Version 10

00001 07-11-01 15:24:55

**[Note]**

- 1, be sure that the fingerprint machine and printer (Super Terminal) have the same baud rate.
- 2, If the default print format can not meet your needs, you contact our business deputy our company is able to present other customized format

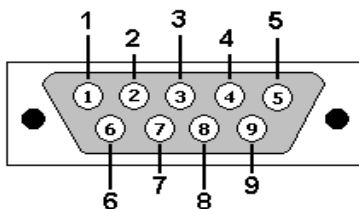

Fingerprint machine                      printer

2 TXD	<----->	3 RXD
3 RXD	<----->	2 TXD
5 GND	<----->	7 FG

**Note: the baud rate of fingerprint machine and printer is same with.**

## MP3 function introduction

So-called MP3 play, is uses the MP3 player to carry on the real-time decompressing MP3 file (decoding), like this, the high quality MP3 music play. The fingerprint machine with the build-in MP3 player is provided with the MP3 play function, is allowed to play the form is MPEG1.0 Layer III mp3 sound. Its playing way is similar with time bell, may set eight time period, will automatically play the mp3 file at time period upon arrival.

According to need you may choose each kind of mp3 file which is assigned as clock in bell sound, midday rests music, but also may make inform from the mp3 file, time carries on the play through the fingerprint machine. Thus meets your each kind of needs, but also causes the work environment to change quietly and tastefully.

Along with the fingerprint machine there is the loudspeaker to play MP3, also may insert the sound box audio output line into the audio jack of the fingerprint machine, and play MP3. Through the sound box

### **MP3 Play Setup**

Open the menu “**Menu Set->Power Management -> Scheduled Bell**”, There are eight period of time is available to set, according to your need to set period of time, after time in range of time period you set, the MP3 will be play automatically.

#### **Note:**

**It is need to set the period of time as the 24 hour format.**

**The 1 period of time against 1.mp3 file, the 2 period of time against 2.mp3. Such –and –such as it do.**

**The fingerprint sensor will be in no responding while the machine is in play MP3 process.**

Press any menu key when the machine is playing MP3, the play process will stop at once

### **MP3 file Save and Read**

Because A6 don't own the capable to save the mp3 file, there are two ways to save and read the mp3 files:

1 By means of Web server save and read mp3 file.

First step, in the menu “**Menu-->Setup-->Power Management-->WEB Master IP**” input the IP address of the computer which has installed the Web server.

Second step, Copy MP3 file to the Web server of compute:

If the Web server (IIS Apache) has been installed in your computer, you can create a MP3 folder in the Virtual Master Virtual Server root directory of Web server, and then copy the playing file to this folder. Input the <http://xxx.xxx.xxx.xxx/mp3/y.mp3> to inspect whether can normally visit MP3 file via IE browser.

If the Web Server hasn't been installed in your compute, you can realize the function via our provided the software, the operation process is following: release the WebServer.rar file to under a directory (to take release to D:\ as a example), to run "webs.exe" under the d:\webserver\web\mp3directory, Web server is running and ensure the Web Server in normally course through all process. And then copy the playing file to d:\webserver\web\mp3 Input the <http://xxx.xxx.xxx.xxx/mp3/y.mp3> to inspect whether can normally visit MP3 file via IE browse

Note: Xxx.xxx.xxx.xxx is an IP address of the computer to install Web server the y.mp3 is the order of mp3 file.

Third step, when arrive at the playing period of time, the machine will read MP3 file via Web server to play

2 By means of U disk to read and save file

Copy the mp3 file to the U disk, after arrive at set playing time the machine will search the file in the U disk to play automatically.

the order of playing MP3file is following: Search the playing file in theWebServer, if it fail to visit Web Server or hasn't defined the file, and the search the playing file in the U disk file, if the are no inserted U disk or no file in the U disk, the machine will play the own ring

### **How to play MP3**

MP3 can via the own loudspeaker to play, and can insert the plug of sound box audio frequency to the left jack of A6,play by means of the sound box.

### **How to adjust Volume**

This machine own the function to adjust the Volume, if the volume of machine playing is improper, Please open “ **Menu->Setup->System setup-> Advance setup-> Volume**” to adjust.

### **MP3 file formats**

This machine supporting format is an mp3 sound file which is the MPEG1.0 Layer III, (this format is a familiar mp3 format, if it is fail to play this file that is likely to too low for the file version format, please charge other file).

### **Test MP3 file**

If you want to test the effect of mp3 playing, you can open the “**menu--> “menu-->setup--> auto- test--> MP3 function test**” to

test.

## Short message management (Optional)

Our some product provide a function which can send a message to assigned person through public to person way, We only need use the back-end software to set it, then upload it to the fingerprint machine, , as long as the attendance dive start the for public short message will be seen on machine screen, and it will show for ever, for a person short message will not display until the user's fingerprint verification is positive, Thus reduces the work load to manager the human power , greatly enhances the working efficiency.

Send a message to a assigned personal if a staff's birthday is on October 20 , we may set back-end software to send out a short message to him “ wish your Happy Birthday” on 20 October , upload it in the machine, after this staff the fingerprint verify successfully on that day, this message will display on the screen

Send a message to public, if entire company needs to have a meet on June 19, after we set back-end software to upload the machine, upon this day, the message “holds XX meet in XX room” will continuously display on the screen, asks everybody (certainly such information you are allowed to revise according to your need) to XX participation”

**Short message function setting** after setting Short message in the Time& Attendance software, then upload it to fingerprint machine, the fingerprint machine support two kind of way to import the short message, which the software connect with fingerprint machine to import it directly, other way by U flash disk.

### **Operation Step as follow**

1. Through Time & Attendance software “external program”-> “short message management” complete to set short message, then connect with the fingerprint machine and upload it, 2. through Time & Attendance software “ external program”-> “ short message management” complete to set short message, choose “ external program”->“U flash disk manage”-> “ export short message”-> “export to U disk”, after exporting successfully, plug the U disk into the fingerprint machine, press “Menu” key of the fingerprint machine”-> “Pendri Mng”-> “ Upload short message”.

**Short message function effect** For public short message will be seen and it will show for ever after this staff the fingerprint verify successfully , this message will display on the screen.

**Note: there is total 1024 items of public for personal short message.**

## Multi-combination Authentication Mode

Besides this function only is owned by the fingerprint access control machine that has been appointed, the most fingerprint machine only has two way to verified by fingerprint and password, we provide a personal or group Multi-combination Authentication Mode for high security Access control area, verification type main include four elements that are Number PIN, Fingerprint (FP), Password (PW) and RF card (RF), which can combine into filth multi-combination.

### Note:

**The fingerprint machine with Mifare function needs to verify Mifare card.**

**The Mifare card is regard as RF card in the verification procedure, the function of Mifare card verification only is validity in the machine which Mifare card function is provided with.**

**These symbols illustrate what follow the table different means.**

- “/” is or,
- “←” is confirm (Enter),
- “+” follow next operation
- “&” is and,

- **FP (fingerprint)**

- **PWD (Password)**

- **RF (RF card)**

- **PIN (user ID)**

If fingerprint or Password has been used to enroll user, the verification procedure is follow

Type	What you do
FP	Only fingerprint is verified.
	1 PIN+FP 1 Verification
	2 FP(1 N Identification) 3 RF+FP(1:1)
PIN	Only PIN is verified
	1 PIN( just have to input the digital through keyboard)
PW	Only verify password is verified
	1 PIN+'' ''+PW
	2 RF+PW
RF	Only RF card is verified
	1 RF
FP/PW	Fingerprint or Password is verified
	1 PIN+FP(1:1)
	2 FP(1:N)
	3 PIN+'' ''+PW
	4 RF+PW
FP/RF	Fingerprint or RF is verified
	1 PIN+FP(1:1)
	2 FP(1:N)
	3 RF
PW/RF	Password or RF is verified

Appendix

---

	<ol style="list-style-type: none"> <li>1 RF</li> <li>2 PIN+” ”+PW</li> </ol>
FP/PW/RF	Fingerprint or RF or Password is verified
	<ol style="list-style-type: none"> <li>1 PIN+FP(1:1)</li> <li>2 FP(1:N)</li> <li>3 PIN+PW</li> <li>4 RF</li> </ol>
FP&PIN	Fingerprint and PIN are verified
	<ol style="list-style-type: none"> <li>1 PIN+” ”+FP(1:1)</li> <li>2 RF+ PIN+” ”+FP(1:1)</li> </ol>
FP&PW	Fingerprint and Password are verified
	<ol style="list-style-type: none"> <li>1 FP(1:N)+PW</li> <li>2 PIN+FP(1:1)+PW</li> <li>3 RF+PW + FP(1:1)</li> </ol>
FP&RF	Fingerprint and RF are verified
	<ol style="list-style-type: none"> <li>1 RF+FP(1:1)</li> <li>2 FP(1:N)+RF</li> <li>3 PIN+FP(1:1)+RF</li> </ol>
PW&RF	Password and RF are verified
	<ol style="list-style-type: none"> <li>1 RF+PW</li> <li>2 PIN+” ”+PW+RF</li> </ol>
FP&PW&RF	Fingerprint, Password and RF are verified
	<ol style="list-style-type: none"> <li>1 FP(1:N)+PW+RF</li> <li>2 PIN+FP(1:1)+PW+RF</li> <li>3 RF+ PW+ FP(1:1)</li> </ol>

FP&PIN&PW	Fingerprint, PIN and Password are verified
	1 PIN+” ”+PW+FP(1:1) 2 RF+ PIN+” ”+PW+FP(1:1)
FP & PIN /RF	Fingerprint and PIN, or fingerprint and RF are verified
	1 FP+ PIN
	2 FP +RF
	3 PIN+FP(1:1) + PIN
4 PIN+FP(1:1) +RF	

**Note:**

- 1) 1: N authentication mode include the 1: H, 1: G authentication.
- 2) In the multi -combination authentication, it is better to use fingerprint and password to enroll, otherwise, sometimes fail to pass verification.

## **Card Support (HID, iCLASS, EM, Mifare Card)**

In order to meet security market need, our fingerprint biometric verification reader can be embedded HID, iCLASS, EM, Mifare reader module.

The HID iCLASS 50 OEM, EM and Mifare module addition that can be used to field upgrade existing fingerprint biometric verification readers to high fingerprint security level.

Using 125MHZ, 13.56 MHz contactless smart card technology, these fingerprint products provide users with new options for supporting multi-authentication of identity. Combine a contactless card presentation with a fingerprint biometric. Or, use a personal identification number (PIN) number along with a contactless card presentation. (See multi-authentication).

The fingerprint products provide three levels of fingerprint verification. During the enrollment process, the LCD prompt will guide the user to place their finger on the sensor. The fingerprint template is collected at the unit and immediately transferred to the card. During this enrollment process, the fingerprint template is stored on the card or the fingerprint machine.

During verification at the door, the LCD graphical display will

assist the user with instructions about finger placement on the biometric sensor.

For more detail see HID, iCLASS, EM, Mifare Card user Guide

## About Anti-pass back function

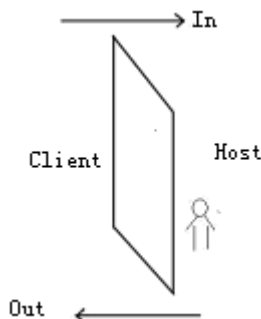

There are two fingerprint machines to control one lock together,

Anti-pass back function to basic hardware request:  
Support Wiegand In, Wiegand Out.

### Work principle

**Master Machine:** Enroll fingerprint, verify fingerprint, configure user's privilege, validate user privilege, and receive the information of card and fingerprint from slave machine, go on verification, then send the result to the slave machine.

**Slave Machine:** it only to be used as reader, achieve these

mission to collect fingerprint, read in card and send information need to be verified to Master machine, the Master machine own the option whether show validation result.

We define the machine that connect with the lock as a master machine, the master machine is capable to support the anti-pass back function; the machine that does not connect with the lock but output Wiegand is a slave machine. The Wiegand Out of the slave machine connect with the Wiegand in of the master machine, there is no the machine No. in the slave machine, the master machine must own the number that the slave machine send out, the user of the two machine which support the Anti-pass back function must be in one by one corresponding. The master machine receives Wiegand that the slave machine output by the Wiegand input.

#### 1) About anti-pass back

Out: Anti-pass back, when the user leave out, the user will be rejected by machine and system alarm

In: This is the auxiliary function, when the user enter but has not the out log, will be the rejected by the machine, and system alarm

In/Out: This is the auxiliary function, the in –out logs must be in pair, if the in –out logs do not match, the machine’s anti-pass back function will be triggered.

#### 2) Anti-pass back menu setting

Anti-pass back: it is allowed to set as “out anti-pass back”, “in anti-pass

back ", "in-out anti-pass back" or "None". (Not until this machine has been set to the master machine, this setting does not take effective.)

### 3) Wiring instruction

the communication between the master and slave machine visa the Wiegand, the wiring shows as follow:

Master machine	slave machine
IND0	WD0
IND1	WD1
GND	GND

## **Instruction to Master and Slave machine feature**

### **1) Save logs**

The default state of Master machine as out, the state of slave machine as in, and all logs is stored in the Master machine.

### **2) Anti-pass back feature**

Depend on record of the user lately in and out to judge whether anti-pass back violation occur, the in and out record must be partnership, this fingerprint machine fully support four type of anti-pass-back, that is out, in or in and out, (enter **menu** →**option**->**system**-> **advanced option** → **anti pass back**), now take “out anti-pass back” as example.

If somebody want to go out.

- 1) He/she lately log record is not in, the system will prompt “Anti-pass back rejects”, rejects to open the door.
- 2) He/she lately log record is in, the system will achieve verification, and open the door.

“In anti-pass back” and “Out anti-pass back” is similar logic “

**Notice Be sure to restart you machine, so the option of anti-pass back take effect.**

### **How to use Master and slave fingerprint machine**

- 2) Configure master menu

Enter “**Menu->Option->System option->advance option**” there are three option here

**Master and slave** This machine can be defined as master by “Master”, slave” or “No” option (after configuring, be sure to restart the machine, this option take effect

**Display slave operation** This option is defined as “Yes”, the slave operation will display on the master, otherwise this operation does not show (this option doesn’t be showed until the machine is defined as master)

Anti- pass back This option may be defined as “Out anti-pass back”, “In anti-pass back”, and In-out anti- pass back” and “no” (this option dose not take effect until be sure restart the machine)

b) Accomplish connection before starting machine, the master machine like as normal access control machine run, and the cline is able to search for slave automatically while it is starting.

## **Remote server Solution**

Because of the limit of standalone machine capacity and speed, there is impossibility to add a large mount of fingerprints (for example, up to ten thousands of fingerprints). Even if the capacity can be expanded, the standalone machine speed can't be assured; the speed is much slower than PC's. Based on above reasons, Standalone is an incapable for those large systems which have large fingerprint capacity and high matching efficiency, so a fingerprint solution, i.e. remote server solution, is put forward, which can deal with large capacity and high efficiency.

### **Concept**

Taking standalone machine as fingerprint scanner, its standalone identification function is reserves. With identification and verification, and then stores matching results in the background DB

and displays identification results on the fingerprint machine LCD, to complete the task of identification process. Which Identification algorithm adopts intellectual property algorithm Biokey the common PCs can act as remote server, the remote sever solution has lower requirement of entire identification system and improve algorithm efficiency, thus assure of feasibility and convenience of solution.

Solution Purpose: large capacity of fingerprint identification, enhanced enterprise internal management, intelligent management, In/Out control for personnel.

### Architecture of Remote server

The basic mode adopts C/S mode, please see the following figure

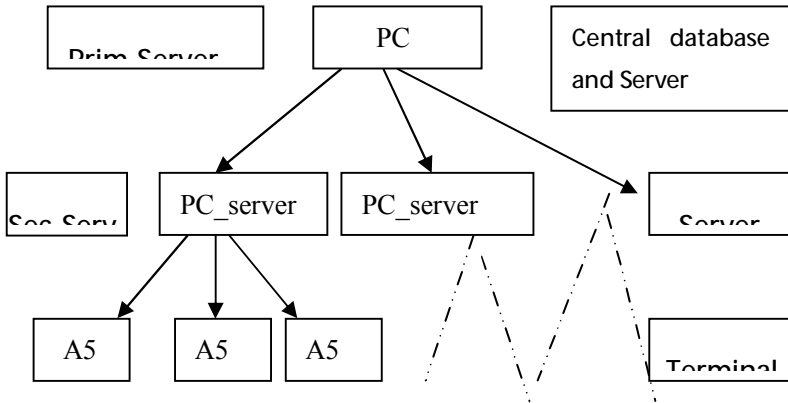

Assign a primary server by logic partition acts as central database. In some large applications, a special server can be selected to make sure that each secondary server can access database fluently, the primary server can also act as remote server, and it is in the secondary server with respect to the role of identification service and identical with other remote server. The only difference between them is that primary server can play dual role, i.e. database service + identification service. At present, database service is SQL Server.

As above the figure show there are three level in, and is divided by logic. The direction of identification data stream is:

Primary Server:

1. Fingerprint Scanning.
2. Successful identification results.
3. Initiation setting of application system.

Secondary Server:

1. Fingerprint data of primary server.
2. Matching fingerprint information passed by third level server

Third level server

1. The fingerprint information will be got in the time of fingerprint press.
2. Keyboard input.

For more detail please (Contact us to get technical assistance)

## **iClock Time & Attendance**

### **IClock Summary**

iClock is a base on Web Server technical Time & Attendance system, use Page. Request technical to process and manage data, it integrate many feature ,such local data collection intellectualized port (RS232/RS485), communication protocol conversion, image collection, alarm data stored up , and WEB server etc. basing on this equipment to create an unifying monitoring platform that supply one solution for equipment management, Time &Attendance, as well as monitor, in addition the Web Time & Attendance solution is independent on regional limit, and do not need to install other software. utilize IE or Netscape browser, downloading and remote on-line management, handle time sheet corrections and create report table on the fingerprint terminal is available , it supply easy way for manager of enterprise know the employ in post or attendance state at any moment, in time search for information, statistic data, deal with operation at same time, provide a solution of staff attendance , check in or out management, pay roll management, in word and deed realize that at everywhere any moment the information is synchronization, its go far beyond traditional Time & Attendance solution

### **Why does embedded Web Server into the fingerprint machine**

1. a few or nobody keep watch

Thought TCP/IP and Ethernet, WEB Server is able to reliable apply to local network, the data fingerprint machine store up can be watch and deal via long distance network with browser it is not need to administrator or person specially assigned go to local for to achieve task collect data, upload and download data, as well as upgrade system, , not have other software and tools

2. Fully compatible with our company Inc program

WEB Server platform may be fully compatible with current program each other entirely is mutually beneficial, ability to much more flexible to meet customer need.

3. More reliable, fast through long distance transfer data

Through WEBSERVER the data is able to reliable and fast be download local system, utilize browse ability to down all data in short time, do not worry about the data's reliability

4. More flexible, easy for data management and source share

Via the platform created by Web server, the application program, data management becomes more easy and flexible.

5. May easy integrate OA, CRM system, reliable base on network human force management.

## How to use iClock serial fingerprint machine

This serial fingerprint machine fully support three connection way—LAN, Dial –Up telephone, internet, though brows visit Web server in the terminal, first login bibcock website, find your terminal, the default name and password is administrator and our company.

**Note: For more detail see (iClock User Guide)**

# Web Server Access Control

## Web Server Access Control Summary

We today announced the release of New Version of Access Control system, New Version was based on Web Server technical and TCP/IP Architecture, use WEB page request to process and manage date, in addition the Web Sever Access Control solution is independent on regional limit, permits downloading and remote on-line management the fingerprint terminal through IE or Netscape browser, handle time sheet corrections and create report table , its go far beyond traditional Access Control Software, It also incorporates the many years of experience of the team.

## The function of built-in Web Server

Please see (iClock Time & Attendance).

**Webserver Software User Guide.**

If you first time user WebSever Software, input the IP address of fingerprint machine, E.g., the fingerprint machine's IP address is 192.168.1.115, input <http://192.168.1.115> in IE address column, the system default super administrator is admin, login password is admin 888.For WebServer software detail, please see (Websever Access Control Explain)

## **Collect IP Address Automatically**

Maybe following circs occur, if there are many fingerprint machines in corporate network, Administer maybe forget the IP address of fingerprint, Administrators can manually check the IP address on system, but it's difficult task, especially when multiple systems are involved, and still leaves much room for error, we develop a software to detect IP address of fingerprint machine in the local network.

Copy all DLLfile under the system 32 of system directory, click start -> run regsvr32 zkemkeeper.dll, the system prompt register successfully, and double-click Machine Search...exe to run software.

## About Wiegand

Wiegand is a commonly used interface between readers and control panels used in access control, security, time and attendance, and other related industries. F Series fingerprint access control machines pursuant the Wiegand standard specified by the Security Industry Association's (SIA) Access Control Standard Protocol for the 26-Bit Wiegand Reader Interface document. Manufacturers have adopted the Wiegand standard to establish a common Wiegand interface. This provides a level of compatibility and interoperability for readers and control panels that can be used by consultants, specifies, and end users when setting product design or system installation criteria.

### Data Signals

Figure 1 displays the timing pattern for data bits sent by the reader to the access control panel. This timing pattern falls within the Wiegand guidelines as proscribed by the SIA's Access Control Standard Protocol for the 26-Bit Wiegand Reader Interface (a Pulse Width time between 20  $\mu$ S and 100  $\mu$ S, and a Pulse Interval time between 200  $\mu$ S and 20 mS). The Data 1 and Data 0 signals are held at logic high level (above the  $V_{oh}$  level) until the reader is ready to send a data stream. The reader places data as asynchronous low-going pulses (below the  $V_{ol}$  level) on the Data 1 or Data 0 lines to transmit the data stream to the access control panel (the “saw-teeth” in Figure 2). The Data 1 and Data 0 pulses will not

overlap or occur simultaneously. Table 1 provides the minimum and maximum allowable pulse width times (the duration of a pulse) and pulse interval times (the time between pulses),

Table1 Pulse

Symbol	Description	Reader typical Time
$T_{pw}$	Pulse Width Time	100 $\mu$ m
$T_{pi}$	Pulse interval time	1ms

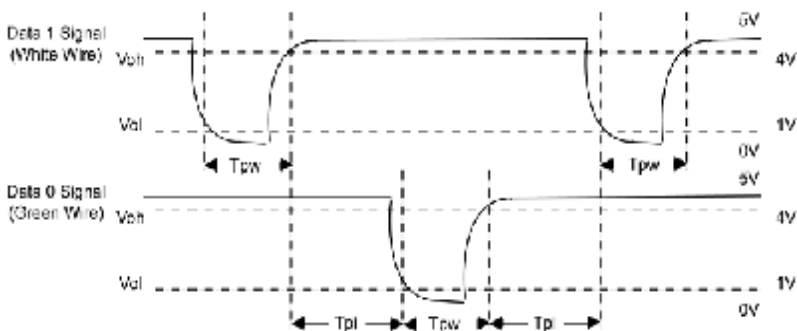

Figure1 Time

## Wigand format

F Series Fingerprint Access Control Wiegand format is a general Access Control protocol.

## 26-bit Wiegand formats

the composition of the open de facto industry standard 26 Bit Wiegand format contains 8 bits for the facility code field and 16 bits for the ID number field .Mathematically these 8 facility code

bits allow for a total of just 256 (0 to 255) facility codes, while the 16 Id number bits allow for a total of only 65,536(0 to 65,535) individual ID's within each facility code.

26-Bit Wiegand length is 26 Bit, it include two parity bit.

<b>1</b>	<b>2</b>	<b>9</b>	<b>10</b>	<b>25</b>	<b>26</b>
<b>E</b>	<b>FC</b>	<b>CC</b>		<b>OP</b>	

Table field definition

Field	Purpose
<b>EP</b>	Even parity bit, over bits 1 to 13 judge EP field, if there are even “ 1”, EP is 0; opposition it is 1.
<b>FC(bit2-bit 9)</b>	Facility code (0-255), Bit 2 is MSB ( most significant bit)
<b>CC (bit10-bit 25)</b>	Card code ,(0-65,535) , bit10 is MSB ( most significant bit)
<b>OP</b>	Odd parity bit, OP is definite by over bit 13 to  26, if there are odd “1” ,opposition it is 0

### Pyramid Wiegand Format

Several alternatives exist for customers who require more codes. The first is to switch to Keri's standard 39 bit Pyramid format. This

39 bit Wiegand format contains 17 bits for the facility code field and 20 bits for the ID number field. Mathematically these 17 facility code bits allow for a total of 131,072 (0 to 131,071) facility codes, while the 20 ID number bits allow for a total of 1,048,576 (0 to 1,048,575) individual ID's within each facility code. Since there are so many facility codes in the Pyramid format, a new facility code may be selected for each project. Additionally the large number of ID's per facility code makes the Pyramid format ideal for very large projects. For added security, Keri Systems tracks credential coding to ensure that no duplication occurs.

Table-3 Pyramid Wiegand Format

Bit Number	Purpose
Bit 1	Even parity over bits 2 to 19
Bits 2 to 18	Facility code (0 to 131,071); Bit 2 is MSB
Bits 19 to 38	ID Number (0 to 1,048,575); Bit 19 is MSB
Bit 39	Odd parity over bits 20 to 38

### Custom Wiegand Formats

The second alternative is to create a custom Wiegand format. Typically, up to 64 bits are available for creating a custom Wiegand format. With certain limitations, formats with greater than 64 bits may be created. If a customer currently has a custom Wiegand format from Wiegand or from other proximity manufacturers, Keri can normally match that format. Although the customer is primarily responsible for custom format card coding, as an added benefit Keri Systems tracks card coding for additional security.

Table-4 Example of a Custom Wiegand Format

Bit Number	Purpose
Bit 1	Even parity over bits 2 to 22
Bits 2 to 9	OEM code (0 to 255); Bit 2 is MSB
Bits 10 to 21	Facility code (0 to 4,096); Bit 10 is MSB
Bits 22 to 43	ID Number (0 to 524,287); Bit 22 is MSB
Bit 44	Odd parity over bits 23 to 43

## Understanding SOAP

### SOAP define

SOAP is a lightweight protocol intended for exchanging structured information in a decentralized, distributed environment. SOAP uses XML technologies to define an extensible messaging framework, which provides a message construct that can be exchanged over a variety of underlying protocols. The framework has been designed to be independent of any particular programming model and other implementation specific semantics.

### SOAP application

Our fingerprint machine can fully support XML-based soap, you can build in soap request in your software, use it to download, upload the user's information, fingerprint information and verification record. It is convenient to import these datum enterprise's database, also can meet enterprise manage employee

and different software request.

**Note** If you want more detail, please contact our technical Assistance.

## **About POE Power over Ethernet**

### **Summary**

Power over Ethernet (PoE) is a revolutionary technology that extends the already ultra-broad functionality of Ethernet by supplying reliable DC power over the same Category 5/5e twisted-pair cable that currently carries Ethernet data. PoE, modeled after the technology used by the telecommunications industry to supply reliable power to telephones, enables lifeline quality power for IP telephones (VoIP) as well as many other low power Ethernet network machines like wireless access points (WAP) and security cameras.

### **POE application**

After putting the fingerprint machine which embedded PoE modeled into PoE system, it is not need to use the adopter to supply

power, its normal work only depend on the PoE supplying, this way provide lower cost and more flexible installation, the table 1 show as the Ethernet RJ45 connector pin number of the fingerprint machine..

Table 1 Ethernet RJ-45 connector pin number (From left to right)

Number	Wire Colour	Source
1	White/Orange	TX+
2	Orange	TX-
3	White/Green	RX+
4	Blue	Power
5	White/Blue	Power
6	Green	RX-
7	White/Brown	GND
8	Brown	GND

### **POE benefit**

*Lower cost.* PoE eliminates the need for running both data and power wires to each network machine. WAPs and security cameras can be installed without the additional expense of contracting an electrician to install AC outlets where deployed. PoE also helps protect IT investments as it is forward and backward compatible with other Ethernet protocols. Furthermore, PoE machines that are Simple Network Management Protocol (SNMP) manageable can be remotely monitored and controlled to efficiently manage or troubleshoot power consumption and/or failures.

- *More flexible.* Network machines can be installed and re-located

where performance is optimum and not tethered to an existing AC outlet. This is especially important for machines like WAPs, which may be installed in hard to reach places like the ceiling in order to achieve the broadest coverage.

- *More reliable.* A SNMP manageable centralized power source enhances the protection against power overloads, outages, surges and spikes. When PoE is implemented, along with uninterruptible power supplies (UPSs) or battery backups, it allows enterprises to distribute power even when the AC electrical power is down. This enables them to replace conventional telephones with feature rich VoIP phones while retaining the lifeline reliability benefits.

## **Reserve Battery Mini-UPS**

It is important to ensure the fingerprint machine power supply under any circumstance, therefore besides of the standard adopter we provide, we also prepare the special 5V Mini-UPS, according to your actual need to purchase it, to extent possibility, help alleviate this problem of the power supply that cause the fingerprint machine down.

### **Work principle**

In normal state the reserve battery is idle state, the fingerprint machine supply with directly current that is translated form alternating current by adopter, if the reserve battery is in

non-saturation state, it will charge up automatically. When the power cut down, the reserve battery will switch into discharge state to power on fingerprint machine.

### How to select reserve battery

model	Discharge hour
ZK-B1 (2000mAh)	3 hors
ZK-B1 (4000mAh)	6 hors

### Connection mode



**Note** Please be sure to connect the Mini-UPS to fingerprint Machine firstly, then power on Mini-UPS.

### Store battery

When storing the batteries, ALWAYS store them at cool and dry room temperature (-10℃ ~ 30℃). DO NOT store the batteries under direct sunlight, higher temperature or high humidity above 3 months storing it is need to keep 50% rating capacity of the battery

(Charge the batteries at least once every three months ), keep the batteries out of the touch deleterious substance, away from fire and hot sources.

## **Notice**

There is a danger of battery exploding, leak, fever, fire, break if you don't read the notice carefully.

- l DO NOT put the battery into water or let it to get wet.
- l Do NOT use and store battery near heat-generating machine  
( such as fire or heater)
  
- l Please use original charger only
  
- l DO NOT inverse polarity connection
  
- l DO NOT plug the batteries directly into the outlet or the cigarette receptacle of a car without inserting a proper charger between the batteries and the outlet or the receptacle.
  
- l DO NOT throw batteries into fire or hot battery. DO NOT use wire or other metal short the positive and negative terminal
- l DO NOT break battery cause short-circuit battery
- l Dropping a battery may cause a strong physical shock that may damage the performance of the battery

## 9 Digit Code

When go on enrolling user in the fingerprint machine, along with the standard enrolling code is five digit its range is 1-65535 , if you need that the enrolling code is longer in the actual application, we can provide a customized design that the fingerprint machine own nine digit code.

## Automatically Synchronize Time

Automatically synchronize time provides the solution to system time maintenance problems. If there are many fingerprint machines in corporate network, Administrators can manually check the time on internal system clocks, but this is a difficult task, especially when multiple systems are involved, and still leaves much room for error. This powerful synchronize time system lets users set up a virtually failsafe synchronized time environment for networks , automatically synchronize time allows creation of custom exact time source in corporate network environment establishing interconnected time synchronization system for each and every machine on the network..

Our fingerprint machine may set as the time Sever and Client, set one fingerprint machine as the Server of corporate network, it is need to set the option of automatically Synchronized Time in

fingerprint machine that want to be calibrate time as time Server IP address , modify the IP address of time client to connect with time server.

E.g. there are many fingerprint machine that are provide with automatically Synchronize Time function we assign the A fingerprint machine as Time Server, it's time show as XX year XX month XX day, XX :00 o'clock , and its IP address as 192.168.1.100. There are M fingerprint machine that need to synchronize time same as A fingerprint machine's, enter the menu of fingerprint machine->option->System option-> advance Option, select automatically synchronize time, set it as Server IP address, after setting finish. Be sure to restart you fingerprint machine so the configuration option take effect, since after an interval of time the fingerprint machine will search for Time Server to Synchronize Time for itself, for more detail to contact us to get technical assistance.

## **Daylight Saving Time**

Some fingerprint machine provides correct and current time in any world time period, country or major city. Accurate adjustments for Daylight Saving Time (or Summer Time) are made according to each location's rules and laws. No matter what time period a country or city is located in, this is your top choice for a clock

resource site.

This function can be set in the fingerprint machine option, Press Manu key, enter the **option->date time**. In the XX Month XX Date XX minute move forward an hour, and that in the XX Month XX Date, XX Minute move Back an hour.

## **Assign time to play voice (by time period, group)**

Along with sound prompt user go on operation in the fingerprint machine, example after the fingerprint authenticate is positive, the fingerprint machine say “ thanking you!”, if the fingerprint authenticate is negative, the machine will prompt “ please put fingerprint again !”. In order to get more satisfy human nature requestment and bring into play voice function, we provide with assign time to play voice that design for carrying on assigned operation depending on different need and send different voice prompt contents, e.g. a staff go on duty at 8 o'clock. When she/he check -in during 6:00-8:00, the fingerprint machine will say “thank you!”, if the staff come lately during 8:00—10:00, the machine will say “be lately, thank you”.

We can realize two type of setting.

By time period: according to time period to assign different sound prompt, for one fingerprint go on operation during a time period

along with a sound, during other time period the fingerprint send other sound.

By group: divide the user into different group, one user group use one sound prompt.

For more detail, please see follow e.g.

- 1 there are eight Time Period Voice to be set availably , enter **menuà Optionà System optionà Advance Option**, select Time Period Voice to set per day Time Period Voice, as follow  
07 00 09 00 hour play,001 10 00 12 00 hour

Time Period Voice				
001	07	00	09	00
002	10	00	12	00
003	00	00	00	00

play002

- 2 After completi configuration ta restart machine, so

004	00	00	00	00
005	00	00	00	00
006	00	00	00	00
007	00	00	00	00
008	00	00	00	00

**Note** If you want more detail, please contact our technical Assistance.

## Work code

We offer the concept about work code that depend on the result of fingerprint verification to distinguish different states and provide convenience for program dealing with record, there is a option in the fingerprint machine which support this function, enter Menu→Option→ Advance Option→ work code, set the work code, For example: we will be defined as a meal, 2defined as to see a doctor, smoking is defined as 3, the different incident is counterparts the value of imported, this software can easily be 1, 2 3 separate incidents.

there are three option mode 1, Mode2, non.

Select the "Mode 1", that is, after the passage of fingerprint authentication, need to input the code (input 1 ~ 9), and press the OK button, the record will work with the input code will be kept together..

Select the "Mode 2", that is, please press the "▲" key input code (input 1 ~ 9), and click the "OK" button pressing fingerprints through fingerprint verification, the records would work with the input code kept together.

Choose mode2 input work code firstly (1-9 digit), the place finger to verify, this verification record and work code you input will store up together.

Choose none, this function will be invalid.

Now the T&A software we provide can store this field into databases while download record, fail to deal with it according to the different category, thereby

Now the standalone communication SDK support second to develop Work code, user may go to advance development. According to the different category to deal with it, thereby it will realize statistic different type of work and way of verification.

NOTE:

- 1) If the test is not passed directly enter any figures on the OK button, the code marker 0.
- 2) the certification after the passage of the code input, but did not press the OK button, the code will be marked as 0
- 3) the certification by the machine will not do anything after the operation, five seconds after the devices will automatically record and save the work code recorded as 0

NOTE:

- 1) If not, "▲" direct certification, can still be verified through, but the record of the work is the code 0.
- 2) Click "▲" after the machine will not do anything operation, wait for 10 seconds , the machine will return to the initial interface.

Select "None" will not activate the feature. Any operation will not be prompted for the code work.

## DHCP

Dynamic Master Configuration Protocol (DHCP) is a standardized protocol that enables clients to be dynamically assigned with various configuration parameters, such as an IP address, subnet mask, default gateway, and other critical network configuration information. DHCP servers centrally manage such configuration data, and are configured by network administrators with settings that are appropriate for a given network environment. DHCP servers in turn communicate with DHCP clients through the use of DHCP messages.

There must be DHCP sever in the network when the DHCP function apply to our fingerprint machine, when the fingerprint machine is connected into network as DHCP client, which will broadcast a message for all local network, after the DHCP sever receive the request and assign a dynamic IP address and DNS according the actual statue in the network.

For the fingerprint machine with this function provided, enter **menu-> option à comm. optionà DHCP**, and set the item as "Y", the fingerprint machine will send a request to DHCP sever to ask for IP address when the fingerprint machine connect to network,

otherwise this item set as “N” , the fingerprint will not send the request.

## **T9 input method**

The name of T9 input method is the smart input method; it is famous for highly effective and quickly inputting the character, this equipment fully supports the T9 Chinese, the T9 English, and the symbol input. There are three or four English letters on 0 ~ 9 numeric keyboards of the machine, for example the numeric keyboard 1 has the A, B, the C three letters, only input key where this letter locate for the T9 Chinese , Press the algorithm of the program will automatically combine the legitimate Pinyin. Then press the numeric key to choose Pinyin for inputting the Chinese character. The T9 English also comply with the letter arrangement of English word to input, only press key which inputs this letter, the program automatically display this key expressed all letters, press the numeric key to select letter. The T9 input method also may input some marks. May input the name, the short message content through the T9 input method user is able to input the name, the short message content.

T9 input method key distribution and its function:

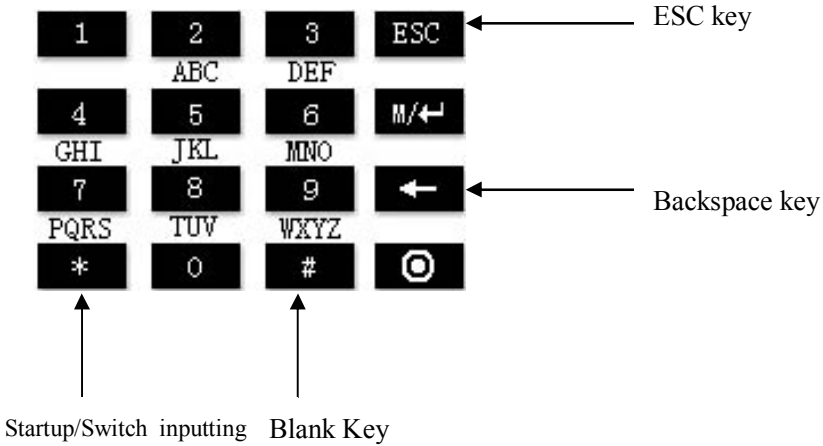

◀/▶ Page up/Down

OK Choose letter

Take an example for the T9 English input: Input "Arabia"  
press the \* numeric key to enter the T9 input method.



Pres OK

Press numeric 2  
key and 3 to input

If must continue, presses the above method again. After the input completed, presses the Scroll ◀/▶ key or input the letter you select.

## About the human rights privacy statement

Dear customer

First thank you for using fingerprint identification product we design and produce. As one of the global famous fingerprint identification core technology provider, we are unceasingly carrying on the development and research, also we believe such action is necessary to: (a) comply with the law or legal process served on Our company; (b) protect and defend the rights or property of Our company (including the enforcement of our agreements); or (c) be governed by related law or legal that involve to the human rights and the privacy in each country. We are committed to protecting your privacy.

We state as follows:

1. Our civil fingerprints identification equipment merely captures fingerprint features point, but not the fingerprint image, does not involve and retain privacy.
2. The fingerprint features points are not to be recovered the primitive fingerprint image, will not involve the privacy.
3. We took an equipment provider, in no state shall we are liable for any direct or the indirect against legal behavior arising out of use or inability use our equipment.
4. If you have the different dispute for close the human rights or the privacy arising out of using our equipment, please directly contacts with your employer.

Our other the police fingerprint equipment or the development kit provide with the function that ability to capture citizen's fingerprint primitive image, as for whether will constitute the right infringement to you, please contact with the local government or the equipment final provider as the equipment original producer, we have not any legal liability for any damage it cause.

**Note:** There are limited rights to privacy and human rights in the Chinese Constitution.

The personal dignity of citizens of the People's Republic of China is inviolable and further, that insult, libel, false accusation or false incrimination directed against citizens by any means is prohibited, the protection of freedom of the person and the residence .The Constitution provides for the freedom and privacy of correspondence of the citizen.

Finally we hereby stressed that once again, as one kind of advanced identification technology the fingerprint identification will apply to electronic commerce, bank, insurance, law service industry in the future, every year, all world cause from the lack of security password , the humanity are suffering the heavy loss. In under high safe and secure environment the fingerprint identification protect your status from damage in fact.